

SOCKET WELD TUBE IN-LINE FLANGES

SAE J518 61 SERIES / ISO6162-1 PATTERN

FLANGE SIZE	TUBE SIZE	PART NUMBER	A	B	C	D	E	F	Gmm	H	K	MOUNTING KIT®			WT
									Jmm			PART NO.	SCREW SIZE	O-RING	
1/2	1/2	1113-08-08M8	1.50	2.12	.75	1.500	.688	.31	8.5	.38	.510	MKM 501	M8 x 30	210	.6
		M8x1.25							-----			---			
1/2	3/4	1113-08-12M8	1.50	2.12	.75	1.500	.688	.50	8.5	.38	.760	MKM 501	M8 x 30	210	.5
		M8x1.25							-----			---			
3/4	3/4	1113-12-12M10	1.75	2.62	1.00	1.875	.875	.50	10.5	.38	.760	MKM 502	M10 x 40	214	.9
		M10x1.5							-----			---			
3/4	1	1113-12-16M10	1.75	2.62	1.00	1.875	.875	.75	10.5	.50	1.010	MKM 502	M10 x 40	214	.8
		M10x1.5							-----			---			
1	1	1113-16-16M10	2.00	2.82	1.00	2.062	1.031	.75	10.5	.50	1.010	MKM 503	M10 x 40	219	1.3
		M10x1.5							-----			---			
1	1 1/4	1113-16-20M10	2.00	2.82	1.00	2.062	1.031	1.00	10.5	.50	1.260	MKM 503	M10 x 40	219	1.2
		M10x1.5							-----			---			
1 1/4	1 1/4	1113-20-20M10†	2.50	3.19	1.00	2.312	1.188	1.00	10.5	.50	1.260	MKM 3524	M10 x 40	222	1.7
		M10x1.5							-----			---			
1 1/4	1 1/2	1113-20-24M10†	2.50	3.19	1.00	2.312	1.188	1.25	10.5	.50	1.510	MKM 3524	M10 x 40	222	1.6
		M10x1.5							-----			---			
1 1/2	1 1/2	1113-24-24M12‡	2.75	3.75	1.25	2.750	1.406	1.25	13.0	.50	1.510	MKM 3596	M12 x 50	225	2.7
		M12x1.75							-----			---			
1 1/2	2	1113-24-32M12‡	2.75	3.75	1.25	2.750	1.406	1.50	13.0	.50	2.010	MKM 3596	M12 x 50	225	2.5
		M12x1.75							-----			---			
2	2	1113-32-32M12‡	3.25	4.00	1.50	3.062	1.688	1.50	13.0	.50	2.010	MKM 3501	M12 x 55	228	4.1
		M12x1.75							-----			---			

MATERIAL:
Low Carbon Steel

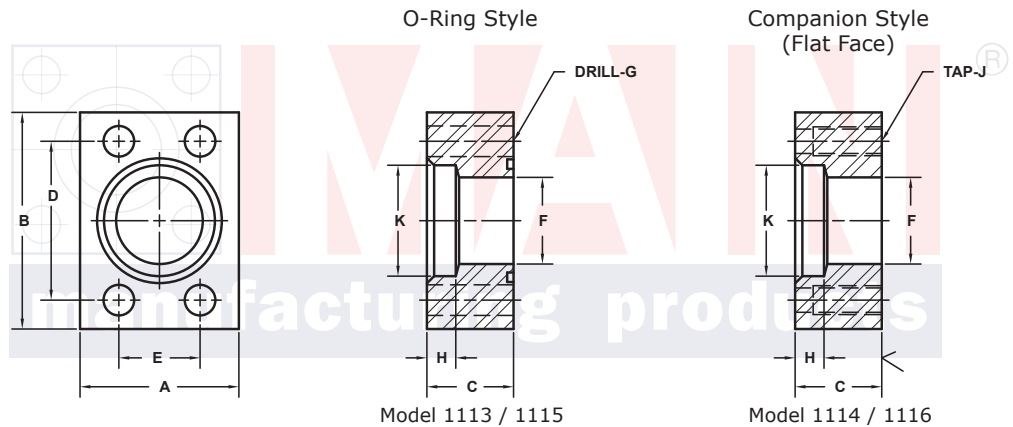
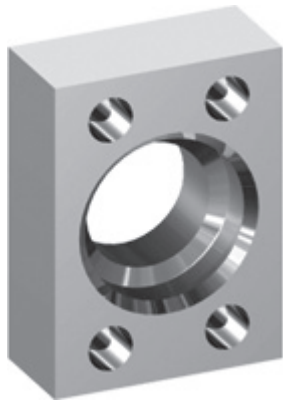

3181 TRI-PARK DR. GRAND BLANC, MI 48439 800-521-7918 810-953-1380 FAX 810-953-1385 INFO@MAINMFG.COM

SAE J518 62 SERIES / ISO6162-2 PATTERN

FLANGE SIZE	TUBE SIZE	PART NUMBER	A	B	C	D	E	F	Gmm	H	K	MOUNTING KIT®			WT
									Jmm			PART NO.	SCREW SIZE	O-RING	
1/2	3/4	1115-08-12M8	1.75	2.22	1.00	1.594	.718	.50	8.5	.50	.760	MKM 512	M8 x 35	210	.8
		M8x1.25							-----			---			
3/4	1	1115-12-16M10	2.00	2.81	1.00	2.000	.937	.75	10.5	.50	1.010	MKM 502	M10 x 40	214	1.2
		M10x1.5							-----			---			
1	1	1115-16-16M12	2.25	3.19	1.00	2.250	1.093	.75	12.5	.50	1.010	MKM 513	M12 x 45	219	1.6
		M12x1.75							-----			---			
1	1 1/4	1115-16-20M12	2.25	3.19	1.00	2.250	1.093	1.00	12.5	.50	1.260	MKM 513	M12 x 45	219	1.5
		M12x1.75							-----			---			
1 1/4	1 1/4	1115-20-20M12‡	2.75	3.75	1.25	2.625	1.250	1.00	13.0	.50	1.260	MKM 1502	M12 x 50	222	2.9
		M12x1.75							-----			---			
1 1/4	1 1/2	1115-20-24M12‡	2.75	3.75	1.25	2.625	1.250	1.25	13.0	.50	1.510	MKM 1502	M12 x 50	222	2.8
		M12x1.75							-----			---			
1 1/2	2	1115-24-32M16	3.25	4.50	1.50	3.125	1.437	1.50	17.0	.50	2.010	MKM 515	M16 x 60	225	4.7
		M16x2							-----			---			
2	2	1115-32-32M20	4.00	5.25	1.75	3.812	1.750	1.50	21.0	.50	2.010	MKM 516	M20 x 70	228	8.3
		M20x2.5							-----			---			

① Order Separately

NOTE: DIMENSIONS ARE IN INCHES UNLESS OTHERWISE NOTED. † Also Available for M12 Bolts ‡ Also Available for M14 Bolts

© Copyright MAIN Mfg. 2017