

NPTF THREADED IN-LINE FLANGES (Pg 1/2)

SAE J518 61 SERIES / ISO6162-1 PATTERN

FLANGE SIZE	PIPE SIZE	PART NUMBER	A	B	C	D	E	F	Gmm	K	MOUNTING KIT®			WT
									Jmm		NPTF	PART NO.	SCREW SIZE	
1/2	1/2	1149-08-08M8	1.50	2.12	1.25	1.500	.688	.50	8.5	1/2	MKM 519	M8 x 45	210	.8
		M8x1.25												
3/4	1/2	1149-12-08M10	1.75	2.62	1.25	1.875	.875	.70	10.5	1/2	MKM 520	M10 x 45	214	1.3
		M10x1.5												
3/4	3/4	1149-12-12M10	1.75	2.62	1.25	1.875	.875	.75	10.5	3/4	MKM 520	M10 x 45	214	1.2
		M10x1.5												
1	3/4	1149-16-12M10	2.00	2.82	1.50	2.062	1.031	.92	10.5	3/4	MKM 521	M10 x 50	219	1.9
		M10x1.5												
1	1	1149-16-16M10	2.00	2.82	1.50	2.062	1.031	1.00	10.5	1	MKM 521	M10 x 50	219	1.7
		M10x1.5												
1 1/4	1	1149-20-16M10†	2.50	3.19	1.50	2.312	1.188	1.16	10.5	1	MKM 3526	M10 x 50	222	2.6
		M10x1.5												
1 1/4	1 1/4	1149-20-20M10†	2.50	3.19	1.50	2.312	1.188	1.25	10.5	1 1/4	MKM 3526	M10 x 50	222	2.3
		M10x1.5												
1 1/4	1 1/2	-----	3.00	3.19	3.00	2.312	1.188	1.25	---	1 1/2	-----	-----	---	6.4
		1150-20-24M10†							M10x1.5					
1 1/2	1 1/4	1149-24-20M12‡	2.75	3.75	1.75	2.750	1.406	1.50	13.0	1 1/4	MKM 2565	M12 x 60	225	3.8
		M12x1.75												
1 1/2	1 1/2	1149-24-24M12‡	2.75	3.75	1.75	2.750	1.406	1.50	13.0	1 1/2	MKM 2565	M12 x 60	225	3.6
		M12x1.75												
1 1/2	2	-----	3.50	3.75	3.50	2.750	1.406	1.50	---	2	-----	-----	---	10.1
		1150-24-32M12‡							M12x1.75					

MATERIAL:
Low Carbon Steel®

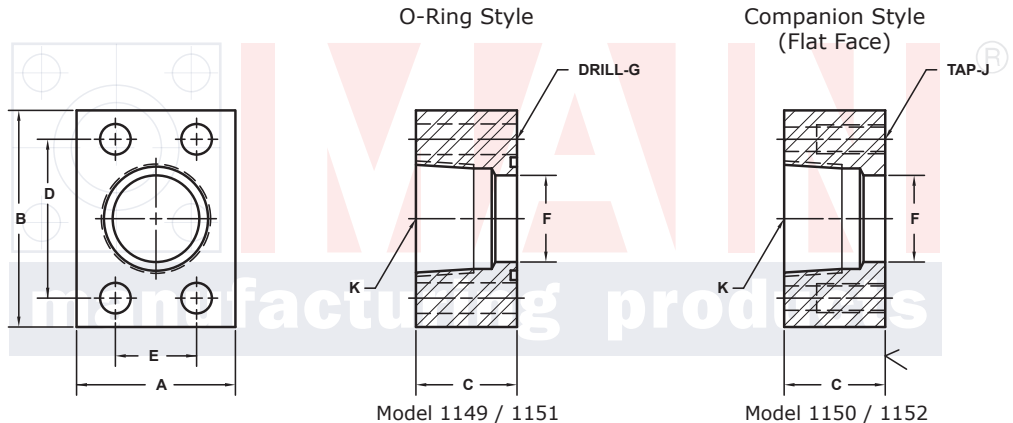
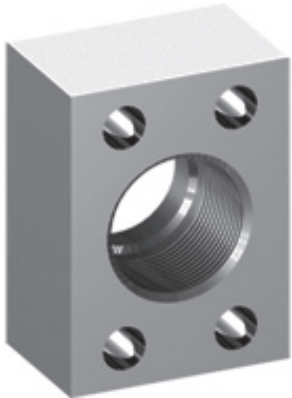

Model 1149 / 1151

Model 1150 / 1152

3181 TRI-PARK DR. GRAND BLANC, MI 48439 800-521-7918 810-953-1380 FAX 810-953-1385 INFO@MAINMFG.COM

SAE J518 62 SERIES / ISO6162-2 PATTERN

FLANGE SIZE	PIPE SIZE	PART NUMBER	A	B	C	D	E	F	Gmm	K	MOUNTING KIT®			WT
									Jmm		NPTF	PART NO.	SCREW SIZE	
1/2	1/2	1151-08-08M8	1.75	2.22	1.25	1.594	.718	.50	8.5	1/2	MKM 519	M8 x 45	210	1.1
		M8x1.25												
3/4	1/2	1151-12-08M10	2.00	2.81	1.25	2.000	.937	.70	10.5	1/2	MKM 520	M10 x 45	214	1.6
		M10x1.5												
3/4	3/4	1151-12-12M10	2.00	2.81	1.25	2.000	.937	.75	10.5	3/4	MKM 520	M10 x 45	214	1.5
		M10x1.5												
1	3/4	1151-16-12M12	2.25	3.19	1.50	2.250	1.093	.92	12.5	3/4	MKM 525	M12 x 55	219	2.4
		M12x1.75												
1	1	1151-16-16M12	2.25	3.19	1.50	2.250	1.093	1.00	12.5	1	MKM 525	M12 x 55	219	2.3
		M12x1.75												
1 1/4	1	1151-20-16M12‡	3.00	3.75	1.50	2.625	1.250	1.16	13.0	1	MKM 522	M12 x 55	222	3.9
		M12x1.75												
1 1/4	1 1/4	1151-20-20M12‡	3.00	3.75	1.50	2.625	1.250	1.25	13.0	1 1/4	MKM 522	M12 x 55	222	3.7
		M12x1.75												
1 1/4	1 1/2	-----	3.00	3.75	3.00	2.625	1.250	1.25	---	1 1/2	-----	-----	---	7.9
		1152-20-24M12‡							M12x1.75					

① Order Separately

® May Contain Lead

NOTE: DIMENSIONS ARE IN INCHES UNLESS OTHERWISE NOTED. † Also Available for M12 Bolts ‡ Also Available for M14 Bolts

© Copyright MAIN Mfg. 2017

NPTF THREADED IN-LINE FLANGES (Pg 2/2)

SAE J518 61 SERIES / ISO6162-1 PATTERN

FLANGE SIZE	PIPE SIZE	PART NUMBER	A	B	C	D	E	F	Gmm		K NPTF	MOUNTING KIT ^①			WT
									Jmm			PART NO.	SCREW SIZE	O-RING	
2	1 1/4	1149-32-20M12 [‡]	3.25	4.00	1.75	3.062	1.688	1.50	13.0		1 1/4	MKM 2566	M12 x 60	228	5.2
		1150-32-20M12 [‡]							M12x1.75	-----		-----	---		
2	1 1/2	1149-32-24M12 [‡]	3.25	4.00	1.75	3.062	1.688	1.74	13.0		1 1/2	MKM 2566	M12 x 60	228	4.9
		1150-32-24M12 [‡]							M12x1.75	-----		-----	---		
2	2	1149-32-32M12 [‡]	3.25	4.00	1.75	3.062	1.688	1.94	13.0		2	MKM 2566	M12 x 60	228	4.2
		1150-32-32M12 [‡]							M12x1.75	-----		-----	---		
2 1/2 ^②	1 1/2	1149-40-24M12 [‡]	4.00	4.50	2.00	3.500	2.000	1.74	13.0		1 1/2	MKM 2574	M12 x 70	232	8.5
		1150-40-24M12 [‡]							M12x1.75	-----		-----	---		
2 1/2 ^②	2	1149-40-32M12 [‡]	4.00	4.50	2.00	3.500	2.000	2.12	13.0		2	MKM 2574	M12 x 70	232	7.5
		1150-40-32M12 [‡]							M12x1.75	-----		-----	---		
2 1/2 ^②	2 1/2	1149-40-40M12 [‡]	4.00	4.50	2.00	3.500	2.000	2.44	13.0		2 1/2	MKM 2574	M12 x 70	232	6.5
		1150-40-40M12 [‡]							M12x1.75	-----		-----	---		
3 ^③	2	1149-48-32M16	4.50	5.50	2.25	4.188	2.438	2.12	17.0		2	MKM 1516	M16 x 80	237	12.5
		1150-48-32M16							M16x2	-----		-----	---		
3 ^③	2 1/2	1149-48-40M16	4.50	5.50	2.25	4.188	2.438	2.62	17.0		2 1/2	MKM 1516	M16 x 80	237	11.4
		1150-48-40M16							M16x2	-----		-----	---		
3 ^③	3	1149-48-48M16	4.50	5.50	2.25	4.188	2.438	2.94	17.0		3	MKM 1516	M16 x 80	237	9.8
		1150-48-48M16							M16x2	-----		-----	---		
3 1/2 ^④	3 1/2	1149-56-56M16	5.00	6.00	2.25	4.750	2.750	3.44	17.0		3 1/2	MKM 2576	M16 x 90	241	11.0
		1150-56-56M16							M16x2	-----		-----	---		
4 ^④	4	1149-64-64M16	5.50	6.50	2.50	5.125	3.062	3.94	17.0		4	MKM 2545	M16 x 90	245	14.5
		1150-64-64M16							M16x2	-----		-----	---		

MATERIAL:
Low Carbon Steel[®]

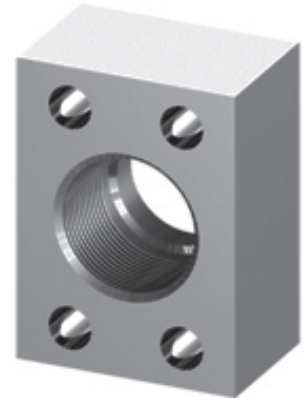
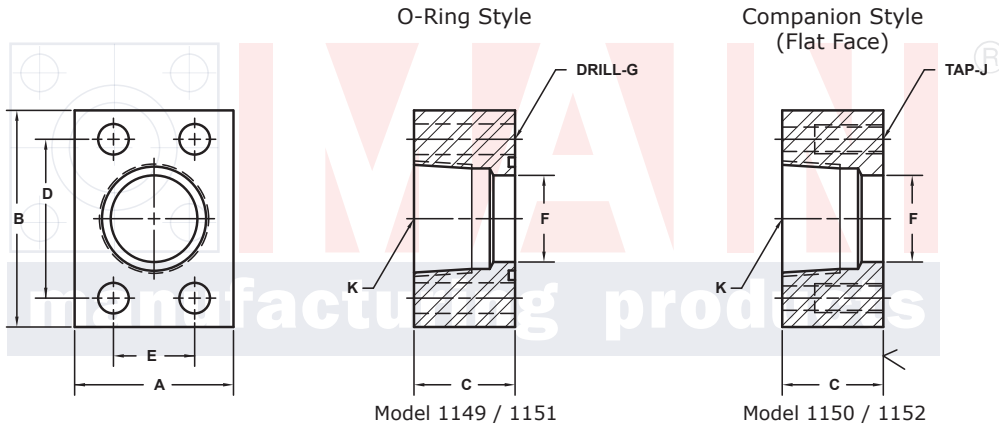

3181 TRI-PARK DR. GRAND BLANC, MI 48439 800-521-7918 810-953-1380 FAX 810-953-1385 INFO@MAINMFG.COM

SAE J518 62 SERIES / ISO6162-2 PATTERN

FLANGE SIZE	PIPE SIZE	PART NUMBER	A	B	C	D	E	F	Gmm		K NPTF	MOUNTING KIT ^①			WT
									Jmm			PART NO.	SCREW SIZE	O-RING	
1 1/2	1 1/4	1151-24-20M16	3.25	4.50	1.75	3.125	1.437	1.50	17.0		1 1/4	MKM 527	M16 x 65	225	5.7
		1152-24-20M16							M16x2	-----		-----	---		
1 1/2	1 1/2	1151-24-24M16	3.25	4.50	1.75	3.125	1.437	1.50	17.0		1 1/2	MKM 527	M16 x 65	225	5.6
		1152-24-24M16							M16x2	-----		-----	---		
1 1/2	2	-----	4.00	4.50	4.00	3.125	1.437	1.50	---		2	-----	-----	---	17.0
		1152-24-32M16							M16x2	-----		-----	---		
2	1 1/2	1151-32-24M20	4.00	5.25	1.75	3.812	1.750	1.74	21.0		1 1/2	MKM 516	M20 x 70	228	8.4
		1152-32-24M20							M20x2.5	-----		-----	---		
2	2	1151-32-32M20	4.00	5.25	1.75	3.812	1.750	1.94	21.0		2	MKM 516	M20 x 70	228	7.8
		1152-32-32M20							M20x2.5	-----		-----	---		
2 1/2	2	1151-40-32M24	5.00	6.88	2.00	4.875	2.312	2.12	25.5		2	MKM 517	M24 x 80	232	15.4
		1152-40-32M24							M24x3	-----		-----	---		
2 1/2	2 1/2	1151-40-40M24	5.00	6.88	2.00	4.875	2.312	2.44	25.5		2 1/2	MKM 517	M24 x 80	232	15.1
		1152-40-40M24							M24x3	-----		-----	---		
3	3	1151-48-48M30	6.00	8.50	2.50	6.000	2.812	2.94	32.0		3	MKM 518	M30 x 110	237	27.5
		1152-48-48M30							M30x3.5	-----		-----	---		

① Order Separately ② 2500 PSI Max ③ 2000 PSI Max ④ 500 PSI Max ⑤ May Contain Lead

NOTE: DIMENSIONS ARE IN INCHES UNLESS OTHERWISE NOTED. † Also Available for M12 Bolts ‡ Also Available for M14 Bolts

© Copyright MAIN Mfg. 2017