

NPTF THREADED BRANCH TEE FLANGES

SAE J518 61 SERIES / ISO6162-1 PATTERN

FLANGE SIZE	PIPE SIZE	PART NUMBER	A	B	C	D	E	F	G		H	K NPTF	MOUNTING KIT®			WT
									Gmm	Jmm			PART NO.	SCREW SIZE	O-RING	
1/2	1/2	1153-08-08M8	2.50	2.12	1.44	1.500	.688	.50	8.5	M8x1.25	1.25	1/2	MKM 541	M8 x 50	210	1.8
		1154-08-08M8							-----				-----	---		
3/4	3/4	1153-12-12M10	3.00	2.62	1.70	1.875	.875	.75	10.5	M10x1.5	1.50	3/4	MKM 542	M10 x 60	214	3.0
		1154-12-12M10							-----				-----	---		
1	3/4	1153-16-12M10	4.00	2.82	1.94	2.062	1.031	1.00	10.5	M10x1.5	2.00	3/4	MKM 543	M10 x 65	219	5.1
		1154-16-12M10							-----				-----	---		
1	1	1153-16-16M10	4.00	2.82	1.94	2.062	1.031	1.00	10.5	M10x1.5	2.00	1	MKM 543	M10 x 65	219	4.8
		1154-16-16M10							-----				-----	---		
1 1/4	3/4	1153-20-12M10†	4.50	3.19	2.40	2.312	1.188	1.25	10.5	M10x1.5	2.25	3/4	MKM 4532	M10 x 75	222	8.0
		1154-20-12M10†							-----				-----	---		
1 1/4	1	1153-20-16M10†	4.50	3.19	2.40	2.312	1.188	1.25	10.5	M10x1.5	2.25	1	MKM 4532	M10 x 75	222	7.7
		1154-20-16M10†							-----				-----	---		
1 1/4	1 1/4	1153-20-20M10†	4.50	3.19	2.40	2.312	1.188	1.25	10.5	M10x1.5	2.25	1 1/4	MKM 4532	M10 x 75	222	7.3
		1154-20-20M10†							-----				-----	---		
1 1/2	1 1/4	1153-24-20M12‡	4.50	3.75	2.90	2.750	1.406	1.50	13.0	M12x1.75	2.25	1 1/4	MKM 4533	M12 x 90	225	12.1
		1154-24-20M12‡							-----				-----	---		
1 1/2	1 1/2	1153-24-24M12‡	4.50	3.75	2.90	2.750	1.406	1.50	13.0	M12x1.75	2.25	1 1/2	MKM 4533	M12 x 90	225	10.2
		1154-24-24M12‡							-----				-----	---		
2	1 1/2	1153-32-24M12‡	5.25	4.00	2.96	3.062	1.688	1.94	13.0	M12x1.75	2.62	1 1/2	MKM 4547	M12 x 90	228	13.0
		1154-32-24M12‡							-----				-----	---		
2	2	1153-32-32M12‡	5.25	4.00	2.96	3.062	1.688	1.94	13.0	M12x1.75	2.62	2	MKM 4547	M12 x 90	228	11.5
		1154-32-32M12‡							-----				-----	---		

MATERIAL:
Low Carbon Steel®

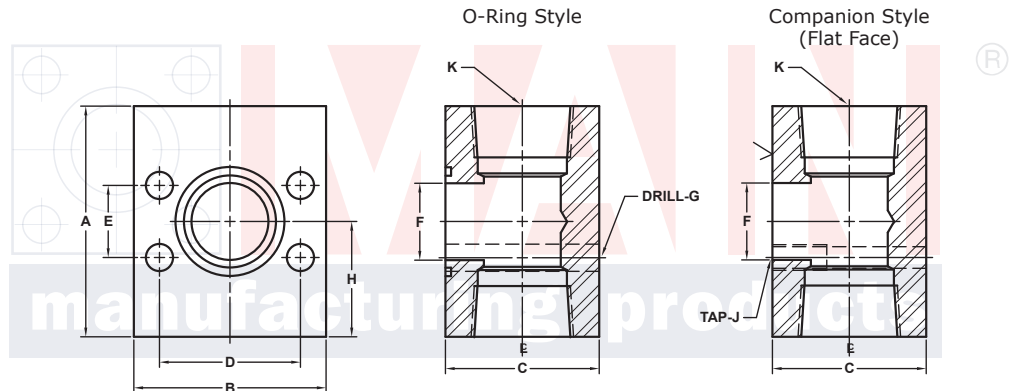

Model 1153 / 1155

Model 1154 / 1156

3181 TRI-PARK DR. GRAND BLANC, MI 48439 800-521-7918 810-953-1380 FAX 810-953-1385 INFO@MAINMFG.COM

SAE J518 62 SERIES / ISO6162-2 PATTERN

FLANGE SIZE	PIPE SIZE	PART NUMBER	A	B	C	D	E	F	G		H	K NPTF	MOUNTING KIT®			WT
									Gmm	Jmm			PART NO.	SCREW SIZE	O-RING	
1/2	1/2	1155-08-08M8	2.50	2.22	1.46	1.594	.718	.50	8.5	M8x1.25	1.25	1/2	MKM 541	M8 x 50	210	2.0
		1156-08-08M8							-----				-----	---		
3/4	3/4	1155-12-12M10	3.00	2.81	1.70	2.000	.937	.75	10.5	M10x1.5	1.50	3/4	MKM 542	M10 x 60	214	3.3
		1156-12-12M10							-----				-----	---		
1	1	1155-16-16M12	4.00	3.19	1.96	2.250	1.093	1.00	12.5	M12x1.75	2.00	1	MKM 551	M12 x 70	219	5.7
		1156-16-16M12							-----				-----	---		
1 1/4	1 1/4	1155-20-20M12‡	4.50	3.75	2.44	2.625	1.250	1.25	13.0	M12x1.75	2.25	1 1/4	MKM 578	M12 x 80	222	9.0
		1156-20-20M12‡							-----				-----	---		
1 1/2	1 1/2	1155-24-24M16	4.50	4.50	2.96	3.125	1.437	1.50	17.0	M16x2	2.25	1 1/2	MKM 553	M16 x 100	225	13.0
		1156-24-24M16							-----				-----	---		
1 1/2	2	1155-24-32M16	5.00	4.50	3.50	3.125	1.437	1.50	17.0	M16x2	2.50	2	MKM	M16 x	225	15.8
		1156-24-32M16							-----				-----	---		
2	1 1/2	1155-32-24M20	6.00	5.25	3.46	3.812	1.750	1.94	21.0	M20x2.5	3.00	1 1/2	MKM 554	M20 x 120	228	24.3
		1156-32-24M20							-----				-----	---		
2	2	1155-32-32M20	6.00	5.25	3.46	3.812	1.750	1.94	21.0	M20x2.5	3.00	2	MKM 554	M20 x 120	228	22.8
		1156-32-32M20							-----				-----	---		

① Order Separately

® May Contain Lead

NOTE: DIMENSIONS ARE IN INCHES UNLESS OTHERWISE NOTED. † Also Available for M12 Bolts ‡ Also Available for M14 Bolts

© Copyright MAIN Mfg. 2017