

FLANGE ADAPTERS

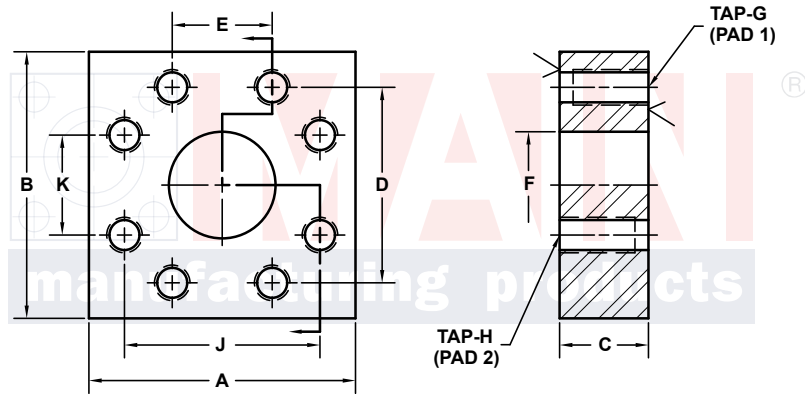
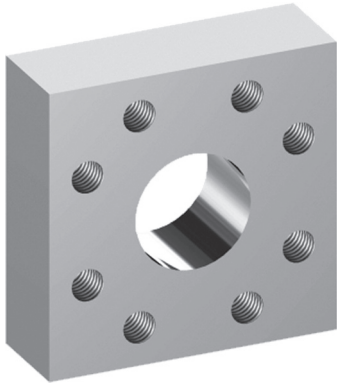

3181 TRI-PARK DR. GRAND BLANC, MI 48439 800-521-7918 810-953-1380 FAX 810-953-1385 INFO@MAINMFG.COM

SAE BOLT PATTERN				62 SERIES TO 61 SERIES ^④									
PAD 1 C62	PAD 2 C61	PART NUMBER	A	B	C	D	E	F	G	H	J	K	
1/2	1/2	1340-08-08					USE 1316-08-08						
3/4	3/4	1340-12-12					USE 1316-12-12						
3/4	1/2	1340-12-08	2.25	2.81	1.75	2.000	.937	.50	3/8-16	5/16-18	1.500	.688	
1	1	1340-16-16					USE 1316-16-16						
1	3/4	1340-16-12	2.75	3.19	1.75	2.250	1.093	.75	7/16-14	3/8-16	1.875	.875	
1	1/2	1340-16-08	2.25	3.19	1.75	2.250	1.093	.50	7/16-14	5/16-18	1.500	.688	
1 1/4	1 1/4	1340-20-20					USE 1316-20-20						
1 1/4	1	1340-20-16	2.75	3.75	1.75	2.625	1.250	1.00	1/2-13	3/8-16	2.062	1.031	
1 1/4	3/4	1340-20-12	2.75	3.75	1.75	2.625	1.250	.75	1/2-13	3/8-16	1.875	.875	
1 1/4	1/2	1340-20-08	2.75	3.75	1.75	2.625	1.250	.50	1/2-13	5/16-18	1.500	.688	
1 1/2	1 1/2	1340-24-24					USE 1316-24-24						
1 1/2	1 1/4	1340-24-20	3.25	4.50	2.00	3.125	1.437	1.25	5/8-11	7/16-14	2.312	1.188	
1 1/2	1	1340-24-16	3.25	4.50	1.75	3.125	1.437	1.00	5/8-11	3/8-16	2.062	1.031	
1 1/2	3/4	1340-24-12	3.25	4.50	1.75	3.125	1.437	.75	5/8-11	3/8-16	1.875	.875	
1 1/2	1/2	1340-24-08	3.25	4.50	1.75	3.125	1.437	.50	5/8-11	5/16-18	1.500	.688	

④ **CAUTION:** Flange adapter pressure rating cannot exceed 61 series pad connection.

FLANGE ADAPTERS

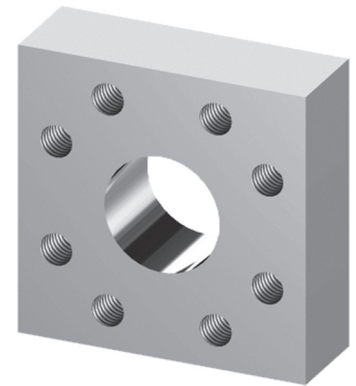
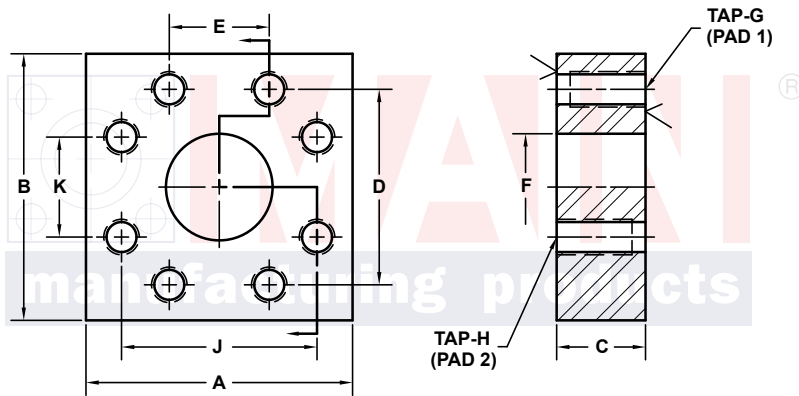

3181 TRI-PARK DR. GRAND BLANC, MI 48439 800-521-7918 810-953-1380 FAX 810-953-1385 INFO@MAINMFG.COM

SAE BOLT PATTERN			62 SERIES TO 61 SERIES ^④										
PAD 1 C62	PAD 2 C61	PART NUMBER	A	B	C	D	E	F	G	H	J	K	
2	2	1340-32-32					USE 1316-32-32						
2	1½	1340-32-24	4.00	5.25	2.00	3.812	1.750	1.50	3/4-10	1/2-13	2.750	1.406	
2	1¼	1340-32-20	4.00	5.25	2.00	3.812	1.750	1.25	3/4-10	7/16-14	2.312	1.188	
2	1	1340-32-16	4.00	5.25	1.75	3.812	1.750	1.00	3/4-10	3/8-16	2.062	1.031	
2	¾	1340-32-12	4.00	5.25	1.75	3.812	1.750	.75	3/4-10	3/8-16	1.875	.875	
2	½	1340-32-08	4.00	5.25	1.75	3.812	1.750	.50	3/4-10	5/16-18	1.500	.688	
2½^③	2½^①	1340-40-40					USE 1316-40-40						
2½^③	2	1340-40-32	5.00	6.88	2.00	4.875	2.312	1.94	7/8-9	1/2-13	3.062	1.688	
2½^③	1½	1340-40-24	5.00	6.88	2.00	4.875	2.312	1.50	7/8-9	1/2-13	2.750	1.406	
2½^③	1¼	1340-40-20	5.00	6.88	2.00	4.875	2.312	1.25	7/8-9	7/16-14	2.312	1.188	
2½^③	1	1340-40-16	5.00	6.88	2.00	4.875	2.312	1.00	7/8-9	3/8-16	2.062	1.031	
2½^③	¾	1340-40-12	5.00	6.88	2.00	4.875	2.312	.75	7/8-9	3/8-16	1.875	.875	
2½^③	½	1340-40-08	5.00	6.88	2.00	4.875	2.312	.50	7/8-9	5/16-18	1.500	.688	
3^③	3^②	1340-48-48					USE 1316-48-48						
3^③	2½^①	1340-48-40	6.00	8.50	2.50	6.000	2.812	2.44	1 1/8-7	1/2-13	3.500	2.000	
3^③	2	1340-48-32	6.00	8.50	2.50	6.000	2.812	1.94	1 1/8-7	1/2-13	3.062	1.688	
3^③	1½	1340-48-24	6.00	8.50	2.50	6.000	2.812	1.50	1 1/8-7	1/2-13	2.750	1.406	
3^③	1¼	1340-48-20	6.00	8.50	2.50	6.000	2.812	1.25	1 1/8-7	7/16-14	2.312	1.188	
3^③	1	1340-48-16	6.00	8.50	2.50	6.000	2.812	1.00	1 1/8-7	3/8-16	2.062	1.031	

① 2500 PSI Max ② 2000 PSI Max ③ Not included in SAE J518 specifications

④ **CAUTION:** Flange adapter pressure rating cannot exceed 61 series pad connection.