

BSPP THREADED ELBOW FLANGES

SAE BOLT PATTERN										61 SERIES					
FLANGE SIZE	PORT SIZE	PART NUMBER	A	B	C	D	E	F	G J	H	K	MOUNTING KIT ^①			WT
												PART NO.	SCREW SIZE	O-RING	
1/2	-8	1359-08-08	2.00	2.12	1.44	1.500	.688	.50	.34	.75	1/2-14	MK 541	5/16-18 x 2	210	1.5
		1360-08-08							5/16-18			-----	---		
3/4	-8	1359-12-08	2.50	2.62	1.70	1.875	.875	.50	.41	.88	1/2-14	MK 542	3/8-16 x 2 1/2	214	2.7
		1360-12-08							3/8-16			-----	---		
3/4	-12	1359-12-12	2.50	2.62	1.70	1.875	.875	.75	.41	.88	3/4-14	MK 542	3/8-16 x 2 1/2	214	2.5
		1360-12-12							3/8-16			-----	---		
1	-12	1359-16-12	3.00	2.82	1.94	2.062	1.031	.75	.41	1.00	3/4-14	MK 543	3/8-16 x 2 3/4	219	3.9
		1360-16-12							3/8-16			-----	---		
1	-16	1359-16-16	3.00	2.82	1.94	2.062	1.031	1.00	.41	1.00	1-11	MK 543	3/8-16 x 2 3/4	219	3.7
		1360-16-16							3/8-16			-----	---		
1 1/4	-20	1359-20-20	3.50	3.19	2.40	2.312	1.188	1.25	.47	1.25	1 1/4-11	MK 578	7/16-14 x 3 1/4	222	5.8
		1360-20-20							7/16-14			-----	---		
1 1/2	-20	1359-24-20	4.00	3.75	2.90	2.750	1.406	1.50	.53	1.38	1 1/4-11	MK 545	1/2-13 x 4	225	9.2
		1360-24-20							1/2-13			-----	---		
1 1/2	-24	1359-24-24	4.00	3.75	2.90	2.750	1.406	1.50	.53	1.38	1 1/2-11	MK 545	1/2-13 x 4	225	9.2
		1360-24-24							1/2-13			-----	---		
2	-20	1359-32-20	4.50	4.00	2.96	3.062	1.688	1.94	.53	1.62	1 1/4-11	MK 558	1/2-13 x 4	228	12.0
		1360-32-20							1/2-13			-----	---		
2	-24	1359-32-24	4.50	4.00	2.96	3.062	1.688	1.94	.53	1.62	1 1/2-11	MK 558	1/2-13 x 4	228	12.0
		1360-32-24							1/2-13			-----	---		
2	-32	1359-32-32	4.50	4.00	3.40	3.062	1.688	1.94	.53	1.62	2-11	MK 546	1/2-13 x 4 1/2	228	12.0
		1360-32-32							1/2-13			-----	---		

MATERIAL:
Low Carbon Steel[®]

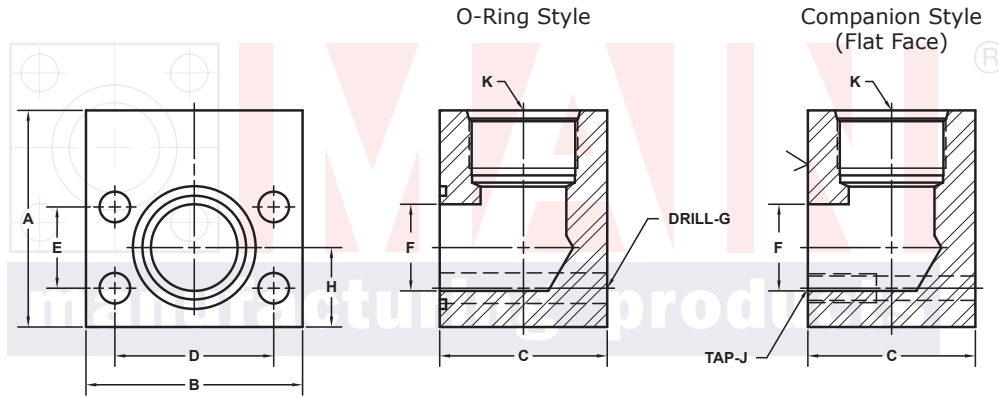

Model 1359 / 1361

Model 1360 / 1362

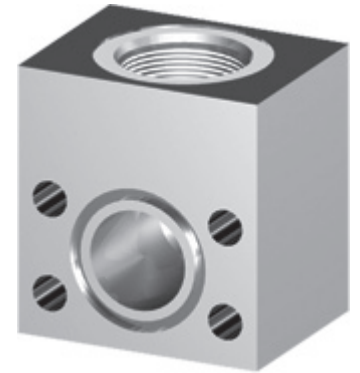

3181 TRI-PARK DR. GRAND BLANC, MI 48439 800-521-7918 810-953-1380 FAX 810-953-1385 INFO@MAINMFG.COM

SAE BOLT PATTERN										62 SERIES					
FLANGE SIZE	PORT SIZE	PART NUMBER	A	B	C	D	E	F	G J	H	K	MOUNTING KIT ^①			WT
												PART NO.	SCREW SIZE	O-RING	
1/2	-8	1361-08-08	2.00	2.22	1.46	1.594	.718	.50	.34	.88	1/2-14	MK 541	5/16-18 x 2	210	1.6
		1362-08-08							5/16-18			-----	---		
3/4	-8	1361-12-08	2.50	2.81	1.70	2.000	.937	.50	.41	1.00	1/2-14	MK 542	3/8-16 x 2 1/2	214	3.0
		1362-12-08							3/8-16			-----	---		
3/4	-12	1361-12-12	2.50	2.81	1.70	2.000	.937	.75	.41	1.00	3/4-14	MK 542	3/8-16 x 2 1/2	214	2.8
		1362-12-12							3/8-16			-----	---		
1	-12	1361-16-12	3.00	3.19	1.96	2.250	1.093	.75	.47	1.12	3/4-14	MK 551	7/16-14 x 2 3/4	219	4.5
		1362-16-12							7/16-14			-----	---		
1	-16	1361-16-16	3.00	3.19	1.96	2.250	1.093	1.00	.47	1.12	1-11	MK 551	7/16-14 x 2 3/4	219	4.3
		1362-16-16							7/16-14			-----	---		
1 1/4	-20	1361-20-20	4.00	3.75	2.44	2.625	1.250	1.25	.53	1.38	1 1/4-11	MK 552	1/2-13 x 3 1/4	222	8.3
		1362-20-20							1/2-13			-----	---		
1 1/2	-24	1361-24-24	4.00	4.50	2.96	3.125	1.437	1.50	.66	1.62	1 1/2-11	MK 553	5/8-11 x 4	225	12.0
		1362-24-24							5/8-11			-----	---		
2	-32	1361-32-32	5.00	5.25	3.46	3.812	1.750	1.94	.78	2.00	2-11	MK 554	3/4-10 x 4 1/2	228	19.7
		1362-32-32							3/4-10			-----	---		

① Order Separately

⑤ May Contain Lead

NOTE: The Pressure Rating of the Assembly Should NOT Exceed the Lower of the Flange Pad or the Fitting. Check the Fitting Manufacturer for Details.