

# SOCKET WELD PIPE IN-LINE FLANGES

WITH -4 ORB (7/16-20) GAUGE PORT ⑥

## SAE J518 61 SERIES / ISO6162-1 PATTERN

FLANGE SIZE	PIPE SIZE	PART NUMBER	A	B	C	D	E	F	Gmm	H	K	MOUNTING KIT①			WT
									Jmm			PART NO.	SCREW SIZE	O-RING	
1/2	1/2	3101-08-08M8	1.50	2.12	1.25	1.500	.688	.50	8.5	.38	.860	MKM 519	M8 x 45	210	.7
		M8x1.25							-----			-----	---		
3/4	3/4	3101-12-12M10	1.75	2.62	1.25	1.875	.875	.75	10.5	.50	1.070	MKM 520	M10 x 45	214	1.2
		M10x1.5							-----			-----	---		
1	1	3101-16-16M10	2.00	2.82	1.25	2.062	1.031	1.00	10.5	.50	1.335	MKM 1501	M10 x 45	219	1.5
		M10x1.5							-----			-----	---		
1 1/4	1 1/4	3101-20-20M10†	2.50	3.19	1.25	2.312	1.188	1.25	10.5	.50	1.680	MKM 4567	M10 x 45	222	2.0
		M10x1.5							-----			-----	---		
1 1/2	1 1/2	3101-24-24M12‡	2.75	3.75	1.25	2.750	1.406	1.50	13.0	.50	1.920	MKM 3596	M12 x 50	225	2.5
		M12x1.75							-----			-----	---		
2	2	3101-32-32M12‡	3.25	4.00	1.50	3.062	1.688	1.94	13.0	.62	2.411	MKM 3501	M12 x 55	228	3.6
		M12x1.75							-----			-----	---		
2 1/2 ②	2 1/2	3101-40-40M12‡	4.00	4.50	1.75	3.500	2.000	2.44	13.0	.75	2.911	MKM 4511	M12 x 60	232	5.7
		M12x1.75							-----			-----	---		
3 ③	3	3101-48-48M16	4.50	5.31	2.00	4.188	2.438	2.94	17.0	.75	3.540	MKM 508	M16 x 75	237	8.3
		M16x2							-----			-----	---		
3 1/2 ④	3 1/2	3101-56-56M16	5.00	6.00	1.50	4.750	2.750	3.44	17.0	.75	4.045	MKM 509	M16 x 65	241	7.7
		M16x2							-----			-----	---		
4 ④	4	3101-64-64M16	5.50	6.38	1.50	5.125	3.062	3.94	17.0	.75	4.550	MKM 510	M16 x 60	245	8.3
		M16x2							-----			-----	---		
5 ④	5	3101-80-80M16	7.00	7.25	2.00	6.000	3.625	4.94	17.0	.75	5.635	MKM 511	M16 x 75	253	14.5
		M16x2							-----			-----	---		

MATERIAL:  
Low Carbon Steel

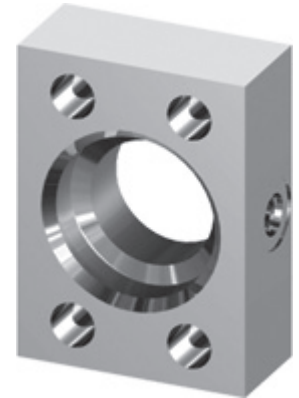
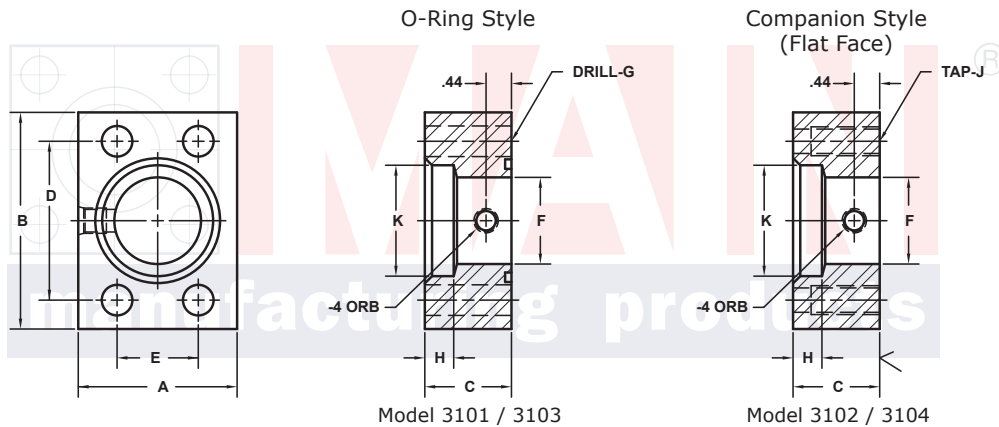

Model 3101 / 3103

Model 3102 / 3104

3181 TRI-PARK DR. GRAND BLANC, MI 48439 800-521-7918 810-953-1380 FAX 810-953-1385 INFO@MAINMFG.COM

## SAE J518 62 SERIES / ISO6162-2 PATTERN

FLANGE SIZE	PIPE SIZE	PART NUMBER	A	B	C	D	E	F	Gmm	H	K	MOUNTING KIT①			WT
									Jmm			PART NO.	SCREW SIZE	O-RING	
1/2	1/2	3103-08-08M8	1.75	2.22	1.25	1.594	.718	.50	8.5	.50	.860	MKM 519	M8 x 45	210	1.1
		M8x1.25							-----			-----	---		
3/4	3/4	3103-12-12M10	2.00	2.81	1.25	2.000	.937	.75	10.5	.50	1.070	MKM 520	M10 x 45	214	1.5
		M10x1.5							-----			-----	---		
1	1	3103-16-16M12	2.25	3.19	1.25	2.250	1.093	1.00	12.5	.50	1.335	MKM 1504	M12 x 50	219	1.9
		M12x1.75							-----			-----	---		
1 1/4	1 1/4	3103-20-20M12‡	2.75	3.75	1.25	2.625	1.250	1.25	13.0	.50	1.680	MKM 1502	M12 x 50	222	2.7
		M12x1.75							-----			-----	---		
1 1/2	1 1/2	3103-24-24M16	3.25	4.50	1.50	3.125	1.437	1.50	17.0	.50	1.920	MKM 515	M16 x 60	225	4.7
		M16x2							-----			-----	---		
2	2	3103-32-32M20	4.00	5.25	1.75	3.812	1.750	1.94	21.0	.62	2.411	MKM 516	M20 x 70	228	7.8
		M20x2.5							-----			-----	---		
2 1/2	2 1/2	3103-40-40M24	5.00	6.88	2.00	4.875	2.312	2.44	25.5	.62	2.911	MKM 517	M24 x 80	232	15.2
		M24x3							-----			-----	---		
3	3	3103-48-48M30	6.00	8.50	2.50	6.000	2.812	2.94	32.0	.62	3.540	MKM 518	M30 x 110	237	27.8
		M30x3.5							-----			-----	---		

① Order Separately ② 2500 PSI Max ③ 2000 PSI Max ④ 500 PSI Max

⑥ Also Available with -6 ORB (9/16-18) GAUGE PORT

NOTE: DIMENSIONS ARE IN INCHES UNLESS OTHERWISE NOTED. † Also Available for M12 Bolts ‡ Also Available for M14 Bolts

© Copyright MAIN Mfg. 2017