

SOCKET WELD PIPE IN-LINE FLANGES

WITH 9/16-18 (-6) SAE GAUGE PORT

SAE J518 61 SERIES / ISO6162-1 PATTERN

FLANGE SIZE	PIPE SIZE	PART NUMBER	A	B	C	D	E	F	G		H	K	MOUNTING KIT®			WT
									Gmm	Jmm			PART NO.	BOLT SIZE	O-RING	
1/2	1/2	4101-08-08M8	1.50	2.12	1.50	1.500	.688	.50	8.5	M8x1.25	.38	.860	MKM 541	M8 x 50	210	1.0
		4102-08-08M8							-----				-----	---		
3/4	3/4	4101-12-12M10	1.75	2.62	1.50	1.875	.875	.75	10.5	M10x1.5	.50	1.070	MKM	M10 x 50	214	1.4
		4102-12-12M10							-----				-----	---		
1	1	4101-16-16M10	2.00	2.82	1.50	2.062	1.031	1.00	10.5	M10x1.5	.50	1.335	MKM 521	M10 x 50	219	1.7
		4102-16-16M10							-----				-----	---		
1 1/4	1 1/4	4101-20-20M10†	2.50	3.19	1.50	2.312	1.188	1.25	10.5	M10x1.5	.50	1.680	MKM 3526	M10 x 50	222	2.3
		4102-20-20M10†							-----				-----	---		
1 1/2	1 1/2	4101-24-24M12‡	2.75	3.75	1.50	2.750	1.406	1.50	13.0	M12x1.75	.50	1.920	MKM	M12 x 55	225	3.0
		4102-24-24M12‡							-----				-----	---		
2	2	4101-32-32M12‡	3.25	4.00	1.75	3.062	1.688	1.94	13.0	M12x1.75	.62	2.411	MKM 2566	M12 x 60	228	4.1
		4102-32-32M12‡							-----				-----	---		
2 1/2 ^②	2 1/2	4101-40-40M12‡	4.00	4.50	1.75	3.500	2.000	2.44	13.0	M12x1.75	.75	2.911	MKM 4511	M12 x 60	232	5.6
		4102-40-40M12‡							-----				-----	---		
3 ^③	3	4101-48-48M16	4.50	5.31	2.00	4.188	2.438	2.94	17.0	M16x2	.75	3.540	MKM 508	M16 x 75	237	8.1
		4102-48-48M16							-----				-----	---		
3 1/2 ^④	3 1/2	4101-56-56M16	5.00	6.00	1.75	4.750	2.750	3.44	17.0	M16x2	.75	4.045	MKM	M16 x 70	241	8.6
		4102-56-56M16							-----				-----	---		
4 ^④	4	4101-64-64M16	5.50	6.38	1.75	5.125	3.062	3.94	17.0	M16x2	.75	4.550	MKM	M16 x 70	245	9.6
		4102-64-64M16							-----				-----	---		
5 ^④	5	4101-80-80M16	7.00	7.25	2.00	6.000	3.625	4.94	17.0	M16x2	.75	5.635	MKM 511	M16 x 75	253	15.6
		4102-80-80M16							-----				-----	---		

MATERIAL:

Low Carbon Steel

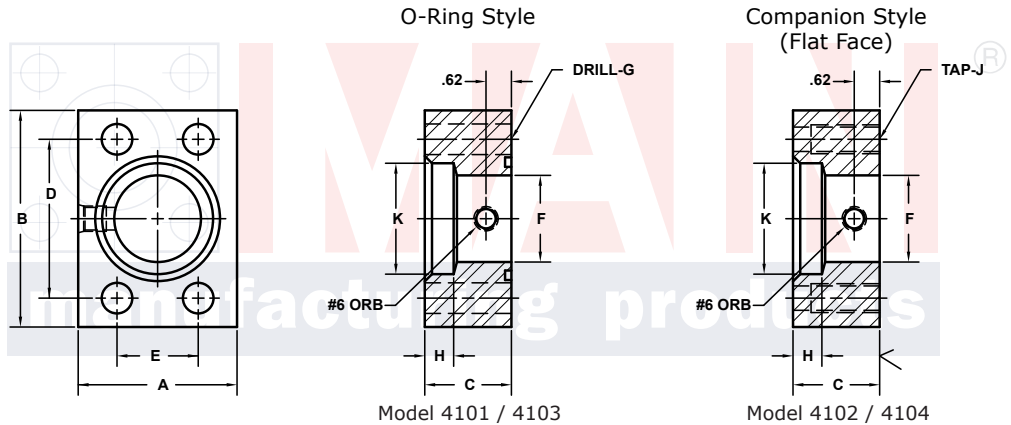
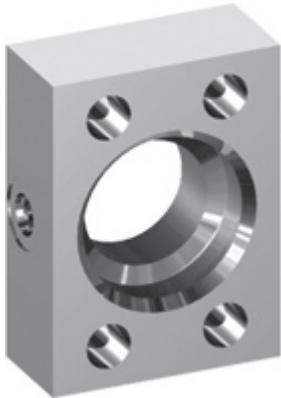

3181 TRI-PARK DR. GRAND BLANC, MI 48439 800-521-7918 810-953-1380 FAX 810-953-1385 INFO@MAINMFG.COM

SAE J518 62 SERIES / ISO6162-2 PATTERN

FLANGE SIZE	PIPE SIZE	PART NUMBER	A	B	C	D	E	F	G		H	K	MOUNTING KIT®			WT
									Gmm	Jmm			PART NO.	BOLT SIZE	O-RING	
1/2	1/2	4103-08-08M8	1.75	2.22	1.50	1.594	.718	.50	8.5	M8x1.25	.50	.860	MKM 541	M8 x 50	210	1.3
		4104-08-08M8							-----				-----	---		
3/4	3/4	4103-12-12M10	2.00	2.81	1.50	2.000	.937	.75	10.5	M10x1.5	.50	1.070	MKM	M10 x 50	214	1.8
		4104-12-12M10							-----				-----	---		
1	1	4103-16-16M12	2.25	3.19	1.50	2.250	1.093	1.00	12.5	M12x1.75	.50	1.335	MKM 525	M12 x 55	219	2.3
		4104-16-16M12							-----				-----	---		
1 1/4	1 1/4	4103-20-20M12‡	2.75	3.75	1.50	2.625	1.250	1.25	13.0	M12x1.75	.50	1.680	MKM 522	M12 x 55	222	3.3
		4104-20-20M12‡							-----				-----	---		
1 1/2	1 1/2	4103-24-24M16	3.25	4.50	1.50	3.125	1.437	1.50	17.0	M16x2	.50	1.920	MKM 515	M16 x 60	225	4.6
		4104-24-24M16							-----				-----	---		
2	2	4103-32-32M20	4.00	5.25	1.75	3.812	1.750	1.94	21.0	M20x2.5	.62	2.411	MKM 516	M20 x 70	228	7.6
		4104-32-32M20							-----				-----	---		
2 1/2	2 1/2	4103-40-40M24	5.00	6.88	2.00	4.875	2.312	2.44	25.5	M24x3	.62	2.911	MKM 517	M24 x 80	232	14.8
		4104-40-40M24							-----				-----	---		
3	3	4103-48-48M30	6.00	8.50	2.50	6.000	2.812	2.94	32.0	M30x3.5	.62	3.540	MKM 518	M30 x 110	237	27.4
		4104-48-48M30							-----				-----	---		

① Order Separately ② 2500 PSI Max ③ 2000 PSI Max ④ 500 PSI Max

NOTE: DIMENSIONS ARE IN INCHES UNLESS OTHERWISE NOTED. † Also Available for M12 Bolts ‡ Also Available for M14 Bolts

© Copyright MAIN Mfg. 2017