

SAE J1926 THREADED FLANGED HEADS

61 SERIES

FLANGE SIZE	ORB	PART NUMBER	A	B	C	D	E	F	G	K	L	O-RING NO. ①	WT
1/2	-8	1245-08-08	2.62	1.188	1.31	.265	.92	.50	1.00	3/4-16	1.000	210	
		1246-08-08									---	---	
3/4	-12	1245-12-12	3.00	1.500	1.75	.265	1.23	.75	1.12	1 1/16-12	1.250	214	
		1246-12-12									---	---	
1	-16	1245-16-16	3.00	1.750	2.00	.315	1.48	1.00	1.12	1 5/16-12	1.562	219	
		1246-16-16									---	---	
1	-20	1245-16-20	3.50	1.750	2.38	.315	1.48	1.00	1.19	1 5/8-12	1.562	219	
		1246-16-20									---	---	
1 1/4	-20	1245-20-20	3.50	2.000	2.38	.315	1.69	1.25	1.19	1 5/8-12	1.750	222	
		1246-20-20									---	---	
1 1/4	-24	1245-20-24	3.62	2.000	2.62	.315	1.69	1.25	1.38	1 7/8-12	1.750	222	
		1246-20-24									---	---	
1 1/2	-24	1245-24-24	3.62	2.375	2.62	.315	1.97	1.50	1.38	1 7/8-12	2.125	225	
		1246-24-24									---	---	
1 1/2	-32	1245-24-32	4.00	2.375	3.50	.315	1.97	1.50	1.12	2 1/2-12	2.125	225	
		1246-24-32									---	---	
2	-32	1245-32-32	4.00	2.812	3.50	.375	2.44	1.94	1.12	2 1/2-12	2.500	228	
		1246-32-32									---	---	
2 1/2 ^②	-32	1245-40-32	4.00	3.312	3.50	.375	2.89	1.94	1.44	2 1/2-12	3.000	232	
		1246-40-32									---	---	

MATERIAL:
Low Carbon Steel^⑤

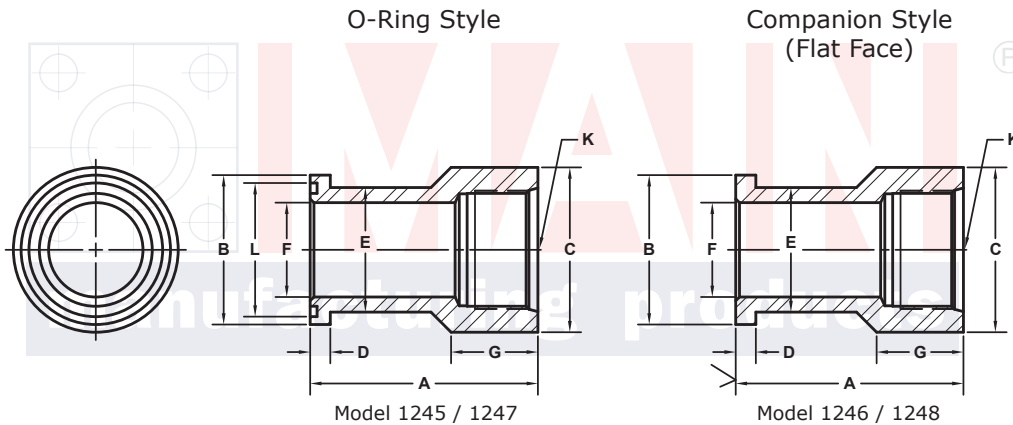

3181 TRI-PARK DR. GRAND BLANC, MI 48439 800-521-7918 810-953-1380 FAX 810-953-1385 INFO@MAINMFG.COM

62 SERIES

FLANGE SIZE	ORB	PART NUMBER	A	B	C	D	E	F	G	K	L	O-RING NO. ①	WT
1/2	-8	1247-08-08	2.75	1.250	1.31	.305	.92	.50	1.06	3/4-16	1.000	210	
		1248-08-08									---	---	
3/4	-12	1247-12-12	3.25	1.625	1.75	.345	1.23	.69	1.31	1 1/16-12	1.250	214	
		1248-12-12									---	---	
1	-16	1247-16-16	3.62	1.875	2.00	.375	1.48	.88	1.25	1 5/16-12	1.562	219	
		1248-16-16									---	---	
1	-20	1247-16-20	4.00	1.875	2.38	.375	1.48	.88	1.31	1 5/8-12	1.562	219	
		1248-16-20									---	---	
1 1/4	-20	1247-20-20	4.00	2.125	2.38	.405	1.69	1.19	1.31	1 5/8-12	1.750	222	
		1248-20-20									---	---	
1 1/2	-24	1247-24-24	4.50	2.500	2.75	.495	1.97	1.38	1.38	1 7/8-12	2.125	225	
		1248-24-24									---	---	
1 1/2	-32	1247-24-32	5.00	2.500	3.50	.495	1.97	1.38	1.38	2 1/2-12	2.125	225	
		1248-24-32									---	---	
2	-32	1247-32-32	4.62	3.125	3.50	.495	2.60	1.75	1.38	2 1/2-12	2.500	228	
		1248-32-32									---	---	

① Order Separately

② 2500 PSI Max

⑤ May Contain Lead

NOTE: The Pressure Rating of the Assembly Should NOT Exceed the Lower of the Flange Pad or the Fitting. Check the Fitting Manufacturer for Details.