

GAUGE PORT ADAPTERS

1/2" GAUGE PORTS

SAE BOLT PATTERN			61 SERIES										
FLANGE SIZE	PIPE SIZE	PART NUMBER	A	B	C	D	E	F	G	L	O-RING ^①	WT	
1/2	NA	1295-08-08	USE PART # 1197-08-08									210	
		1297-08-08	USE PART # 1201-08-08										
3/4	NA	1295-12-12	USE PART # 1197-12-08									214	
		1297-12-12	USE PART # 1201-12-08										
1	NA	1295-16-16	2.00	2.82	1.50	2.062	1.031	1.00	.41	1.562	219	1.7	
		1297-16-16											
1 1/4	NA	1295-20-20	2.50	3.19	1.50	2.312	1.188	1.25	.47	1.750	222	2.5	
		1297-20-20											
1 1/2	NA	1295-24-24	2.75	3.75	1.50	2.750	1.406	1.50	.53	2.125	225	3.2	
		1297-24-24											
2	NA	1295-32-32	3.25	4.00	1.50	3.062	1.688	1.94	.53	2.500	228	3.8	
		1297-32-32											
2 1/2 ^②	NA	1295-40-40	4.00	4.50	1.75	3.500	2.000	2.44	.53	3.000	232	6.0	
		1297-40-40											
3 ^③	NA	1295-48-48	4.50	5.31	2.00	4.188	2.438	2.94	.66	3.625	237	8.8	
		1297-48-48											

MATERIAL:
Low Carbon Steel^⑤

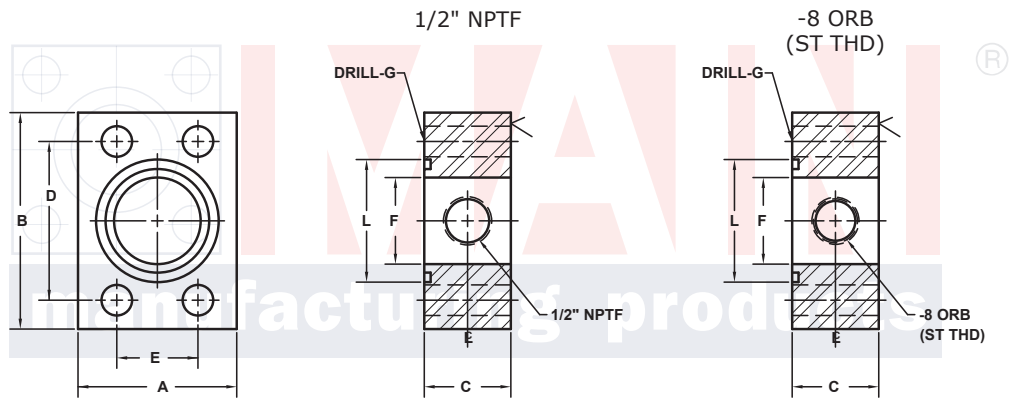

Model 1295 / 1296

Model 1297 / 1298

3181 TRI-PARK DR. GRAND BLANC, MI 48439 800-521-7918 810-953-1380 FAX 810-953-1385 INFO@MAINMFG.COM

SAE BOLT PATTERN			62 SERIES										
FLANGE SIZE	PIPE SIZE	PART NUMBER	A	B	C	D	E	F	G	L	O-RING ^①	WT	
1/2	NA	1296-08-08	USE PART # 1199-08-08									210	
		1298-08-08	USE PART # 1203-08-08										
3/4	NA	1296-12-12	USE PART # 1199-12-08									214	
		1298-12-12	USE PART # 1203-12-08										
1	NA	1296-16-16	2.25	3.19	1.50	2.250	1.093	1.00	.47	1.562	219	2.3	
		1298-16-16											
1 1/4	NA	1296-20-20	3.00	3.75	1.50	2.625	1.250	1.25	.53	1.750	222	3.8	
		1298-20-20											
1 1/2	NA	1296-24-24	3.25	4.50	1.50	3.125	1.437	1.50	.66	2.125	225	4.7	
		1298-24-24											
2	NA	1296-32-32	4.00	5.25	1.75	3.812	1.750	1.94	.78	2.500	228	7.8	
		1298-32-32											

① Includes Buna-N O-Ring ② 2500 PSI Max ③ 2000 PSI Max

⑤ May Contain Lead