

BUTT WELD IN-LINE FLANGES

For Schedule 160 Pipe ⑥

ISO 6164 BOLT PATTERN										250 BAR SERIES																																			
FLANGE SIZE	PIPE SIZE	PART NUMBER	A	B	C	Dmm	E	F	Gmm Jmm	H	K	MOUNTING KIT®			WT																														
												PART NO.	SCREW SIZE	O-RING																															
13	1/2	1647-08-08M	4.00	2.00	2.25	98	2.728	1.69	17.5 M16x2	1.60	2.50	MKM 3531	M16 x 65	228	6.0																														
		1648-08-08M										-----	---																																
19	3/4	1647-12-12M										4.75	2.38	2.50		118	3.285	2.12	22.0 M20x2.5	1.88	3.00	MKM 5573	M20 x 80	232	9.4																				
		1648-12-12M																				-----	---																						
25	1	1647-16-16M																				5.50	2.75	3.00		145	4.037	2.62	22.0 M20x2.5	2.28	3.50	MKM 5558	M20 x 90	237	15.7										
		1648-16-16M																														-----	---												
32	1 1/4	1647-20-20M																														PLEASE USE THE 400 BAR SERIES FOUND BELOW. THE BLOCK SIZE, BOLT PATTERN AND THE O-RING ARE IDENTICAL IN FLANGE SIZES 13 - 38. IF YOU HAVE ANY QUESTIONS PLEASE CALL ENGINEERING AT 1-800-521-7918.													
		1648-20-20M																																											
38	1 1/2	1647-24-24M																																											
		1648-24-24M																																											
51	2	1647-32-32M																																											
		1648-32-32M																																											
56	2 1/2	1647-40-40M																																											
		1648-40-40M																																											
63	3	1647-48-48M																																											
		1648-48-48M																																											

MATERIAL:
Low Carbon Steel

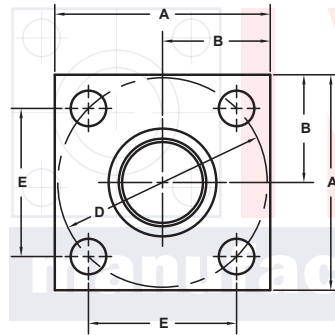
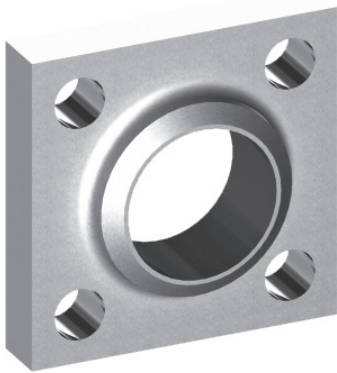

O-Ring Style

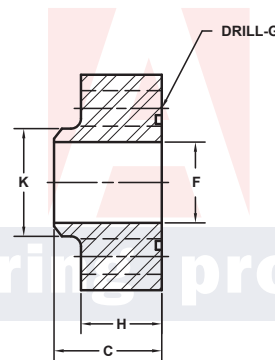

Model 1647 / 1651

Companion Style (Flat Face)

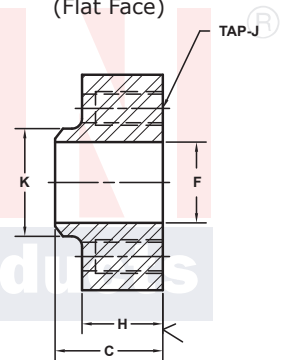

Model 1648 / 1652

3181 TRI-PARK DR. GRAND BLANC, MI 48439 800-521-7918 810-953-1380 FAX 810-953-1385 INFO@MAINMFG.COM

ISO 6164 BOLT PATTERN										400 BAR SERIES					
FLANGE SIZE	PIPE SIZE	PART NUMBER	A	B	C	Dmm	E	F	Gmm Jmm	H	K	MOUNTING KIT®			WT
												PART NO.	SCREW SIZE	O-RING	
13	1/2	1651-08-08M	1.75	.88	1.12	42	1.170	.47	9.0	.81	.88	MKM 512	M8 x 35	210	.7
		1652-08-08M							M8x1.25			-----	---		
19	3/4	1651-12-12M	2.00	1.00	1.25	50	1.392	.61	9.0	.90	1.12	MKM 5559	M8 x 35	214	1.0
		1652-12-12M							M8x1.25			-----	---		
25	1	1651-16-16M	2.50	1.25	1.50	62	1.726	.81	11.0	1.00	1.38	MKM 503	M10 x 40	219	1.7
		1652-16-16M							M10x1.5			-----	---		
32	1 1/4	1651-20-20M	3.00	1.50	1.75	73	2.032	1.16	13.5	1.20	1.75	MKM 1502	M12 x 50	222	2.7
		1652-20-20M							M12x1.75			-----	---		
38	1 1/2	1651-24-24M	3.50	1.75	2.00	85	2.366	1.34	17.5	1.44	2.00	MKM 515	M16 x 60	225	4.2
		1652-24-24M							M16x2			-----	---		
51	2	1651-32-32M	4.00	2.00	2.25	98	2.728	1.69	17.5	1.60	2.50	MKM 5560	M16 x 65	331	6.1
		1652-32-32M							M16x2			-----	---		
56	2 1/2	1651-40-40M	4.75	2.38	2.75	118	3.285	2.12	22.0	1.98	3.00	MKM 5538	M20 x 80	335	10.1
		1652-40-40M							M20x2.5			-----	---		
63	3	1651-48-48M	6.00	3.00	3.00	145	4.037	2.62	26.0	2.12	3.50	MKM 5561	M24 x 90	337	17.5
		1652-48-48M							M24x3			-----	---		
70	3 1/2	1651-56-56M	6.50	3.25	3.50	160	4.454	2.73	26.0	2.46	4.00	MKM 5562	M24 x 100	340	25.0
		1652-56-56M							M24x3			-----	---		
80	4	1651-64-64M	7.00	3.50	4.00	175	4.872	3.15	33.0	2.85	4.50	MKM 5563	M30 x 120	341	31.5
		1652-64-64M							M30x3.5			-----	---		

① Order Separately

⑥ Other Pipe and Tube Sizes are Available

NOTE: Dimensions are in Inches Unless Otherwise Noted.

© Copyright MAIN Mfg. 2017