

SOCKET WELD PIPE IN-LINE FLANGES

3000 SERIES SQUARE BOLT PATTERN

FLANGE SIZE	PIPE SIZE	PART NUMBER	A	B	C	D	E	F	G		H	K	MOUNTING KIT®			WT
									J				PART NO.	SCREW SIZE	O-RING	
3/4	3/4	1387-12-12	2.25	1.12	1.00	.719	1.438	.75	.41	.50	1.070	MK 528	3/8-16 x 1 3/4	216	1.1	
		1388-12-12							3/8-16			-----	---			
1	1	1387-16-16	3.00	1.50	1.00	1.000	2.000	1.00	.53	.50	1.335	MK 529	1/2-13 x 1 3/4	222	2.0	
		1388-16-16							1/2-13			-----	---			
1 1/4	1 1/4	1387-20-20	3.00	1.50	1.00	1.000	2.000	1.25	.53	.50	1.680	MK 529	1/2-13 x 1 3/4	222	1.8	
		1388-20-20							1/2-13			-----	---			
1 1/2	1 1/2	1387-24-24	4.00	2.00	1.25	1.375	2.750	1.50	.66	.62	1.920	MK 530	5/8-11 x 2 1/4	228	4.4	
		1388-24-24							5/8-11			-----	---			
2	2	1387-32-32	4.00	2.00	1.25	1.375	2.750	1.94	.66	.62	2.411	MK 530	5/8-11 x 2 1/4	228	3.8	
		1388-32-32							5/8-11			-----	---			
2 1/2	2 1/2	1387-40-40	5.50	2.75	1.50	1.875	3.750	2.44	.94	.75	2.911	MK 531	7/8-9 x 2 3/4	236	9.5	
		1388-40-40							7/8-9			-----	---			
3	3	1387-48-48	5.50	2.75	1.50	1.875	3.750	2.88	.94	.75	3.540	MK 531	7/8-9 x 2 3/4	236	8.4	
		1388-48-48							7/8-9			-----	---			
3 1/2	3 1/2	1387-56-56	6.00	3.00	1.75	2.125	4.250	3.38	.94	.75	4.045	MK 589	7/8-9 x 3	240	10.7	
		1388-56-56							7/8-9			-----	---			
4	4	1387-64-64	7.00	3.50	2.00	2.500	5.000	3.88	1.06	.75	4.550	MK 572	1-8 x 3 1/2	347	18.3	
		1388-64-64							1-8			-----	---			
5	5	1387-80-80	8.00	4.00	2.50	3.000	6.000	4.81	1.06	1.00	5.635	MK 590	1-8 x 4	355	28.0	
		1388-80-80							1-8			-----	---			
6	6	1387-96-96	10.00	5.00	2.50	3.500	7.000	5.75	1.31	1.00	6.697	MK 573	1 1/4-7 x 4 1/2	362	46.0	
		1388-96-96							1 1/4-7			-----	---			

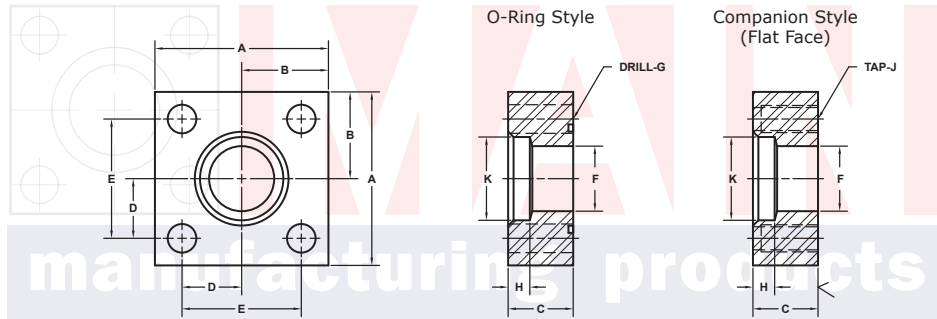
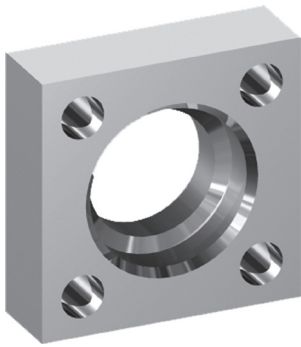

MATERIAL: **Low Carbon Steel** Model 1387 / 1389 Model 1388 / 1390

3181 TRI-PARK DR. GRAND BLANC, MI 48439 800-521-7918 810-953-1380 FAX 810-953-1385 INFO@MAINMFG.COM

6000 SERIES SQUARE BOLT PATTERN

FLANGE SIZE	PIPE SIZE	PART NUMBER	A	B	C	D	E	F	G		H	K	MOUNTING KIT®			WT
									J				PART NO.	SCREW SIZE	O-RING	
1/2	1/2	1389-08-08	2.25	1.12	1.00	.719	1.438	.50	.41	.50	.860	MK 2501	3/8-16 x 1 3/4	210	1.2	
		1390-08-08							3/8-16			-----	---			
3/4	3/4	1389-12-12	2.50	1.25	1.00	.875	1.750	.61	.41	.50	1.070	MK 2502	3/8-16 x 1 3/4	214	1.4	
		1390-12-12							3/8-16			-----	---			
1	1	1389-16-16	3.00	1.50	1.00	1.000	2.000	.81	.53	.50	1.335	MK 2503	1/2-13 x 2	219	2.0	
		1390-16-16							1/2-13			-----	---			
1 1/4	1 1/4	1389-20-20	4.00	2.00	1.25	1.375	2.750	1.16	.66	.50	1.680	MK 2504	5/8-11 x 2 1/2	222	4.7	
		1390-20-20							5/8-11			-----	---			
1 1/2	1 1/2	1389-24-24	4.00	2.00	1.50	1.375	2.750	1.34	.66	.62	1.920	MK 2505	5/8-11 x 2 3/4	225	5.4	
		1390-24-24							5/8-11			-----	---			
2	2	1389-32-32	5.00	2.50	1.75	1.750	3.500	1.69	.78	.62	2.411	MK 2506	3/4-10 x 3 1/2	228	10.2	
		1390-32-32							3/4-10			-----	---			
2 1/2	2 1/2	1389-40-40	5.50	2.75	1.75	1.875	3.750	2.12	.94	.75	2.911	MK 2507	7/8-9 x 3 1/2	232	11.6	
		1390-40-40							7/8-9			-----	---			
3	3	1389-48-48	7.00	3.50	2.00	2.375	4.750	2.62	1.06	.75	3.540	MK 2508	1-8 x 4	236	22.0	
		1390-48-48							1-8			-----	---			
3 1/2	3 1/2	1389-56-56	8.00	4.00	2.50	2.750	5.500	3.00	1.31	1.00	4.045	MK 2509	1 1/4-7 x 5	342	35.5	
		1390-56-56							1 1/4-7			-----	---			
4	4	1389-64-64	8.50	4.25	2.50	3.000	6.000	3.44	1.31	1.00	4.550	MK 2510	1 1/4-7 x 5	346	38.6	
		1390-64-64							1 1/4-7			-----	---			
5	5	1389-80-80	10.00	5.00	3.00	3.625	7.250	4.31	1.56	1.12	5.635	MK 2511	1 1/2-6 x 6	353	63.3	
		1390-80-80							1 1/2-6			-----	---			

① Order Separately