

# BUTT WELD IN-LINE FLANGES

For Schedule 80 Pipe ©

## 3000 SERIES SQUARE BOLT PATTERN

FLANGE SIZE	PIPE SIZE	PART NUMBER	A	B	C	D	E	F	G		H	K	MOUNTING KIT®			WT	
									J				PART NO.	SCREW SIZE	O-RING		
3/4	3/4	1399-12-12	2.25	1.12	1.25	.719	1.438	.75		.41		.38	1.12	MK 528	3/8-16 x 1 3/4	216	1.1
		3/8-16								-----				---			
1	1	1399-16-16	3.00	1.50	1.25	1.000	2.000	.94		.53		.38	1.38	MK 529	1/2-13 x 1 3/4	222	1.6
		1/2-13								-----				---			
1 1/4	1 1/4	1399-20-20	3.00	1.50	1.25	1.000	2.000	1.25		.53		.38	1.75	MK 529	1/2-13 x 1 3/4	222	1.5
		1/2-13								-----				---			
1 1/2	1 1/2	1399-24-24	4.00	2.00	1.50	1.375	2.750	1.50		.66		.50	2.00	MK 581	5/8-11 x 2	228	3.2
		5/8-11								-----				---			
2	2	1399-32-32	4.00	2.00	1.50	1.375	2.750	1.94		.66		.50	2.50	MK 581	5/8-11 x 2	228	3.1
		5/8-11								-----				---			
2 1/2	2 1/2	1399-40-40	5.50	2.75	1.75	1.875	3.750	2.32		.94		.50	3.00	MK 1519	7/8-9 x 2 1/2	236	7.3
		7/8-9								-----				---			
3	3	1399-48-48	5.50	2.75	1.75	1.875	3.750	2.90		.94		.50	3.50	MK 1519	7/8-9 x 2 1/2	236	6.7
		7/8-9								-----				---			
3 1/2	3 1/2	1399-56-56	6.00	3.00	1.75	2.125	4.250	3.36		.94		.50	4.00	MK 1577	7/8-9 x 2 1/2	240	9.7
		7/8-9								-----				---			
4	4	1399-64-64	7.00	3.50	2.00	2.500	5.000	3.83		1.06		.50	4.50	MK 1578	1-8 x 3	347	15.5
		1-8								-----				---			
5	5	1399-80-80	8.00	4.00	2.50	3.000	6.000	4.81		1.06		.50	5.62	MK 1579	1-8 x 3 1/2	355	25.2
		1-8								-----				---			
6	6	1399-96-96	10.00	5.00	2.50	3.500	7.000	5.75		1.31		.50	6.75	MK 5533	1 1/4-7 x 4	362	40.4
		1 1/4-7								-----				---			

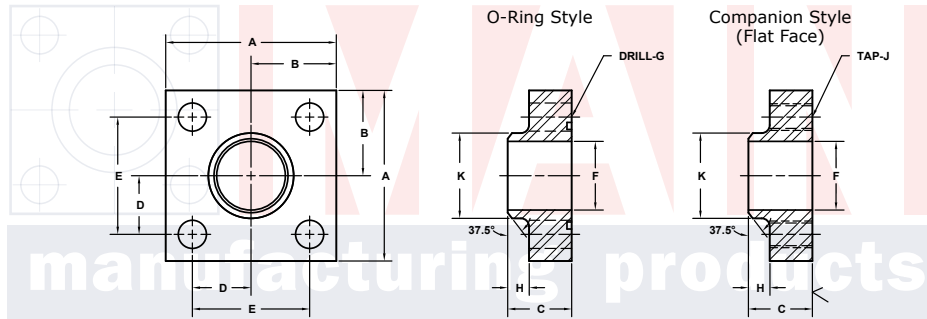

MATERIAL: **Low Carbon Steel** Model 1399 / 1401 Model 1400 / 1402  
 3181 TRI-PARK DR. GRAND BLANC, MI 48439 800-521-7918 810-953-1380 FAX 810-953-1385 INFO@MAINMFG.COM

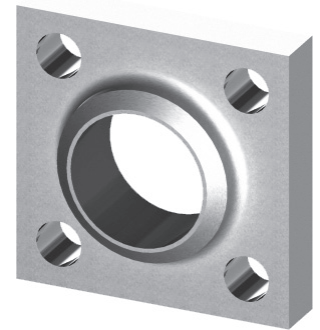

## 6000 SERIES SQUARE BOLT PATTERN

FLANGE SIZE	PIPE SIZE	PART NUMBER	A	B	C	D	E	F	G		H	K	MOUNTING KIT®			WT	
									J				PART NO.	SCREW SIZE	O-RING		
1/2	1/2	1401-08-08	2.25	1.12	1.50	.719	1.438	.53		.41		.50	.88	MK 2501	3/8-16 x 1 3/4	210	1.5
		3/8-16								-----				---			
3/4	3/4	1401-12-12	2.50	1.25	1.50	.875	1.750	.75		.41		.50	1.12	MK 2502	3/8-16 x 1 3/4	214	1.8
		3/8-16								-----				---			
1	1	1401-16-16	3.00	1.50	1.50	1.000	2.000	.94		.53		.50	1.38	MK 2503	1/2-13 x 2	219	2.4
		1/2-13								-----				---			
1 1/4	1 1/4	1401-20-20	4.00	2.00	1.75	1.375	2.750	1.25		.66		.50	1.75	MK 2504	5/8-11 x 2 1/2	222	5.1
		5/8-11								-----				---			
1 1/2	1 1/2	1401-24-24	4.00	2.00	2.00	1.375	2.750	1.50		.66		.50	2.00	MK 2505	5/8-11 x 2 3/4	225	6.0
		5/8-11								-----				---			
2	2	1401-32-32	5.00	2.50	2.25	1.750	3.500	1.94		.78		.50	2.50	MK 2506	3/4-10 x 3 1/2	228	11.0
		3/4-10								-----				---			
2 1/2	2 1/2	1401-40-40	5.50	2.75	2.25	1.875	3.750	2.32		.94		.50	3.00	MK 2507	7/8-9 x 3 1/2	232	12.5
		7/8-9								-----				---			
3	3	1401-48-48	7.00	3.50	2.50	2.375	4.750	2.90		1.06		.50	3.50	MK 2508	1-8 x 4	236	23.0
		1-8								-----				---			
3 1/2	3 1/2	1401-56-56	8.00	4.00	3.50	2.750	5.500	3.36		1.31		1.00	4.00	MK 2509	1 1/4-7 x 5	342	37.0
		1 1/4-7								-----				---			
4	4	1401-64-64	8.50	4.25	3.50	3.000	6.000	3.83		1.31		1.00	4.50	MK 2510	1 1/4-7 x 5	346	41.0
		1 1/4-7								-----				---			
5	5	1401-80-80	10.00	5.00	4.00	3.625	7.250	4.81		1.56		1.00	5.62	MK 2511	1 1/2-6 x 6	353	65.5
		1 1/2-6								-----				---			

① Order Separately

© Schedules 40, 160 and XXS also Stocked. Other Pipe and Tube Sizes are Available