

# SAE J1926 THREADED IN-LINE FLANGES

## 3000 SERIES SQUARE BOLT PATTERN

FLANGE SIZE	ORB	PART NUMBER	A	B	C	D	E	F	G	K	MOUNTING KIT®			WT
									J		PART NO.	SCREW SIZE	O-RING	
1/2	-6	1439-08-06	2.25	1.12	1.25	.719	1.438	.47	.41	9/16-18	MK 580	3/8-16 x 1 1/4	216	1.5
		1440-08-06							-----		-----	---		
1/2	-8	1439-08-08	2.25	1.12	1.25	.719	1.438	.50	.41	3/4-16	MK 580	3/8-16 x 1 1/4	216	1.5
		1440-08-08							-----		-----	---		
3/4	-10	1439-12-10	2.25	1.12	1.25	.719	1.438	.50	.41	7/8-14	MK 580	3/8-16 x 1 1/4	216	1.4
		1440-12-10							-----		-----	---		
3/4	-12	1439-12-12	2.25	1.12	1.50	.719	1.438	.75	.41	1 1/16-12	MK 1522	3/8-16 x 1 1/2	216	1.4
		1440-12-12							-----		-----	---		
1	-14	1439-16-14	3.00	1.50	1.50	1.000	2.000	.75	.53	1 3/16-12	MK 1523	1/2-13 x 1 1/2	222	2.8
		1440-16-14							-----		-----	---		
1	-16	1439-16-16	3.00	1.50	1.50	1.000	2.000	1.00	.53	1 5/16-12	MK 1523	1/2-13 x 1 1/2	222	2.7
		1440-16-16							-----		-----	---		
1 1/4	-20	1439-20-20	3.00	1.50	1.50	1.000	2.000	1.25	.53	1 5/8-12	MK 1523	1/2-13 x 1 1/2	222	2.5
		1440-20-20							-----		-----	---		
1 1/2	-20	1439-24-20	4.00	2.00	1.75	1.375	2.750	1.50	.66	1 5/8-12	MK 1524	5/8-11 x 1 3/4	228	6.0
		1440-24-20							-----		-----	---		
1 1/2	-24	1439-24-24	4.00	2.00	1.75	1.375	2.750	1.50	.66	1 7/8-12	MK 1524	5/8-11 x 1 3/4	228	5.7
		1440-24-24							-----		-----	---		
2	-32	1439-32-32	4.00	2.00	1.75	1.375	2.750	1.94	.66	2 1/2-12	MK 1524	5/8-11 x 1 3/4	228	4.8
		1440-32-32							-----		-----	---		
2 1/2	-32	1439-40-32	5.50	2.75	2.25	1.875	3.750	2.32	.94	2 1/2-12	MK 1519	7/8-9 x 2 1/2	236	13.3
		1440-40-32							-----		-----	---		

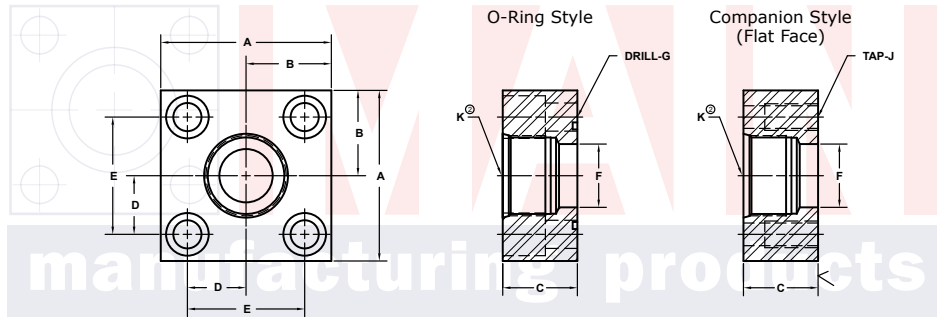
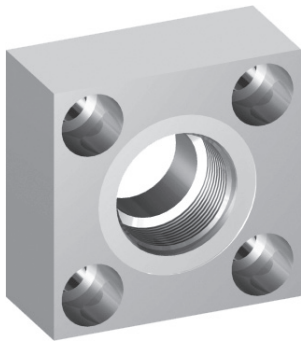

MATERIAL: **Low Carbon Steel**® Model 1439 / 1441 Model 1440 / 1442

3181 TRI-PARK DR. GRAND BLANC, MI 48439 800-521-7918 810-953-1380 FAX 810-953-1385 INFO@MAINMFG.COM

## 6000 SERIES SQUARE BOLT PATTERN

FLANGE SIZE	ORB	PART NUMBER	A	B	C	D	E	F	G	K	MOUNTING KIT®			WT
									J		PART NO.	SCREW SIZE	O-RING	
1/2	-6	1441-08-06	2.25	1.12	1.25	.719	1.438	.47	.41	9/16-18	MK 4544	3/8-16 x 1 1/4	210	1.5
		1442-08-06							-----		-----	---		
1/2	-8	1441-08-08	2.25	1.12	1.25	.719	1.438	.50	.41	3/4-16	MK 4544	3/8-16 x 1 1/4	210	1.5
		1442-08-08							-----		-----	---		
3/4	-10	1441-12-10	2.50	1.25	1.25	.875	1.750	.62	.41	7/8-14	MK 1543	3/8-16 x 1 1/4	214	2.2
		1442-12-10							-----		-----	---		
3/4	-12	1441-12-12	2.50	1.25	1.50	.875	1.750	.75	.41	1 1/16-12	MK 1525	3/8-16 x 1 1/2	214	2.1
		1442-12-12							-----		-----	---		
1	-14	1441-16-14	3.00	1.50	1.50	1.000	2.000	.75	.53	1 3/16-12	MK 5542	1/2-13 x 1 1/2	219	2.9
		1442-16-14							-----		-----	---		
1	-16	1441-16-16	3.00	1.50	1.50	1.000	2.000	1.00	.53	1 5/16-12	MK 5542	1/2-13 x 1 1/2	219	2.8
		1442-16-16							-----		-----	---		
1 1/4	-16	1441-20-16	4.00	2.00	1.50	1.375	2.750	1.20	.66	1 5/16-12	MK 5556	5/8-11 x 1 3/4	222	5.4
		1442-20-16							-----		-----	---		
1 1/4	-20	1441-20-20	4.00	2.00	1.50	1.375	2.750	1.25	.66	1 5/8-12	MK 5556	5/8-11 x 1 3/4	222	5.0
		1442-20-20							-----		-----	---		
1 1/2	-24	1441-24-24	4.00	2.00	1.75	1.375	2.750	1.50	.66	1 7/8-12	MK 562	5/8-11 x 2	225	5.8
		1442-24-24							-----		-----	---		
2	-24	1441-32-24	5.00	2.50	1.75	1.750	3.500	1.75	.78	1 7/8-12	MK 563	3/4-10 x 2	228	9.0
		1442-32-24							-----		-----	---		
2	-32	1441-32-32	5.00	2.50	1.75	1.750	3.500	1.94	.78	2 1/2-12	MK 563	3/4-10 x 2	228	8.7
		1442-32-32							-----		-----	---		

① Order Separately

® May Contain Lead

**NOTE:** The pressure rating of the assembly should not exceed the lower of the flange pad or the fitting. Check the fitting manufacturer for details.