

SOCKET WELD PIPE IN-LINE FLANGES

For JIS O-Ring and JIS Pipe ©

JIS B 2291 BOLT PATTERN (210K)										TYPE SHA & SHB (TAPPED)					
FLANGE SIZE	PIPE SIZE	PART NUMBER	A	B	C	Emm	E	F	Gmm Jmm	H	K	MOUNTING KIT®			WT
												PART NO.	SCREW SIZE	O-RING	
15	15	1501-08-08M	2.50	1.25	.87	40.0	1.574	.63	11.0	.43	.874	MKM 4771	M10 x 40	G25	1.3
		1504-08-08M							M10x1.5			-----	---		
20	20	1501-12-12M	2.75	1.38	.87	45.0	1.772	.81	11.0	.47	1.091	MKM 4772	M10 x 40	G30	1.5
		1504-12-12M							M10x1.5			-----	---		
25	25	1501-16-16M	3.25	1.62	1.10	53.0	2.086	.98	13.0	.55	1.358	MKM 4773	M12 x 50	G35	2.5
		1504-16-16M							M12x1.75			-----	---		
32	32	1501-20-20M	3.50	1.75	1.10	63.0	2.480	1.24	13.0	.63	1.701	MKM 4774	M12 x 50	G40	2.9
		1504-20-20M							M12x1.75			-----	---		
40	40	1501-24-24M	4.00	2.00	1.38	70.0	2.756	1.48	18.0	.71	1.933	MK 4775	M16 x 60	G50	4.7
		1504-24-24M							M16x2			-----	---		
50	50	1501-32-32M	4.50	2.25	1.38	80.0	3.150	1.87	18.0	.79	2.406	MKM 4776	M16 x 60	G60	5.7
		1504-32-32M							M16x2			-----	---		
65	65	1501-40-40M	5.50	2.75	1.75	100.0	3.937	2.36	22.0	.86	3.035	MKM 4777	M20 x 75	G75	10.4
		1504-40-40M							M20x2.5			-----	---		
80	80	1501-48-48M	6.25	3.12	1.75	112.0	4.409	2.80	24.0	.98	3.543	MKM 4778	M22 x 80	G85	13.0
		1504-48-48M							M22x2.5			-----	---		

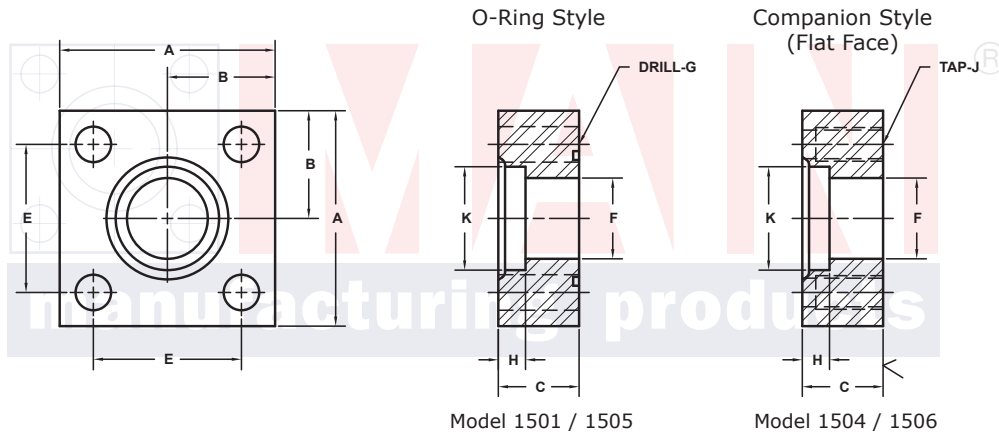

MATERIAL:
Low Carbon Steel

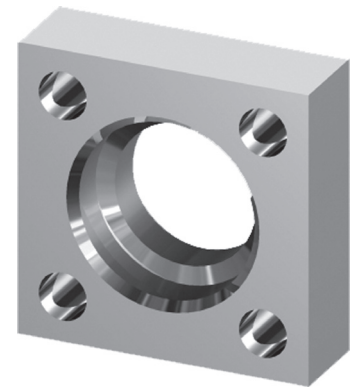

3181 TRI-PARK DR. GRAND BLANC, MI 48439 800-521-7918 810-953-1380 FAX 810-953-1385 INFO@MAINMFG.COM

JIS B 2291 BOLT PATTERN (210K)										TYPE SSA & SSB					
FLANGE SIZE	PIPE SIZE	PART NUMBER	A	B	C	Emm	E	F	Gmm Jmm	H	K	MOUNTING KIT®			WT
												PART NO.	SCREW SIZE	O-RING	
15	15	1505-08-08M	2.25	1.12	.87	36.0	1.417	.63	11.0	.43	.874	MKM 4571	M10 x 40	G25	1.0
		1506-08-08M							M10x1.5			-----	---		
20	20	1505-12-12M	2.25	1.12	.87	40.0	1.574	.81	11.0	.47	1.091	MKM 4572	M10 x 40	G30	.9
		1506-12-12M							M10x1.5			-----	---		
25	25	1505-16-16M	2.75	1.38	1.10	48.0	1.890	.98	13.0	.55	1.358	MKM 4573	M12 x 50	G35	1.7
		1506-16-16M							M12x1.75			-----	---		
32	32	1505-20-20M	3.00	1.50	1.10	56.0	2.205	1.24	13.0	.63	1.701	MKM 4574	M12 x 50	G40	1.4
		1506-20-20M							M12x1.75			-----	---		
40	40	1505-24-24M	3.75	1.88	1.38	65.0	2.559	1.48	18.0	.71	1.933	MKM 4575	M16 x 60	G50	3.9
		1506-24-24M							M16x2			-----	---		
50	50	1505-32-32M	4.00	2.00	1.38	73.0	2.874	1.87	18.0	.79	2.406	MKM 4576	M16 x 60	G60	4.3
		1506-32-32M							M16x2			-----	---		
65	65	1505-40-40M	5.00	2.50	1.75	92.0	3.622	2.36	22.0	.86	3.035	MKM 4577	M20 x 75	G75	8.6
		1506-40-40M							M20x2.5			-----	---		
80	80	1505-48-48M	5.50	2.75	1.75	103.0	4.055	2.80	24.0	.98	3.543	MKM 4578	M22 x 80	G85	9.5
		1506-48-48M							M22x2.5			-----	---		

① Order Separately

© Also Available for JIS O-Ring and American Pipe or American O-Ring and American Pipe

NOTE: Dimensions are in Inches Unless Otherwise Noted.

© Copyright MAIN Mfg. 2017