

BLIND FLANGES

SAE BOLT PATTERN										61 SERIES				
FLANGE SIZE	PIPE SIZE	PART NUMBER	A	B	C	D	E	G	J	MOUNTING KIT®			WT	
										PART NO.	SCREW SIZE	O-RING		
1/2	NA	1101-08-00	1.50	2.12	.75	1.500	.688			.34	MK 501	5/16-18 x 1 1/4	210	.7
		1102-08-00								5/16-18	-----	---		
3/4	NA	1101-12-00	1.75	2.62	1.00	1.875	.875			.41	MK 502	3/8-16 x 1 3/4	214	1.2
		1102-12-00								3/8-16	-----	---		
1	NA	1101-16-00	2.00	2.82	1.00	2.062	1.031			.41	MK 503	3/8-16 x 1 3/4	219	1.5
		1102-16-00								3/8-16	-----	---		
1 1/4	NA	1101-20-00	2.50	3.19	1.00	2.312	1.188			.47	MK 504	7/16-14 x 1 3/4	222	2.0
		1102-20-00								7/16-14	-----	---		
1 1/2	NA	1101-24-00	2.75	3.75	1.25	2.750	1.406			.53	MK 505	1/2-13 x 2	225	3.3
		1102-24-00								1/2-13	-----	---		
2	NA	1101-32-00	3.25	4.00	1.50	3.062	1.688			.53	MK 506	1/2-13 x 2 1/4	228	5.2
		1102-32-00								1/2-13	-----	---		
2 1/2 ^②	NA	1101-40-00	4.00	4.50	1.75	3.500	2.000			.53	MK 507	1/2-13 x 2 1/2	232	8.5
		1102-40-00								1/2-13	-----	---		
3 ^③	NA	1101-48-00	4.50	5.31	2.00	4.188	2.438			.66	MK 508	5/8-11 x 3	237	12.8
		1102-48-00								5/8-11	-----	---		
3 1/2 ^④	NA	1101-56-00	5.00	6.00	1.50	4.750	2.750			.66	MK 509	5/8-11 x 2 1/2	241	12.3
		1102-56-00								5/8-11	-----	---		
4 ^④	NA	1101-64-00	5.50	6.38	1.50	5.125	3.062			.66	MK 510	5/8-11 x 2 1/2	245	14.5
		1102-64-00								5/8-11	-----	---		
5 ^④	NA	1101-80-00	7.00	7.25	2.00	6.000	3.625			.66	MK 511	5/8-11 x 3	253	28.1
		1102-80-00								5/8-11	-----	---		

MATERIAL:
Low Carbon Steel

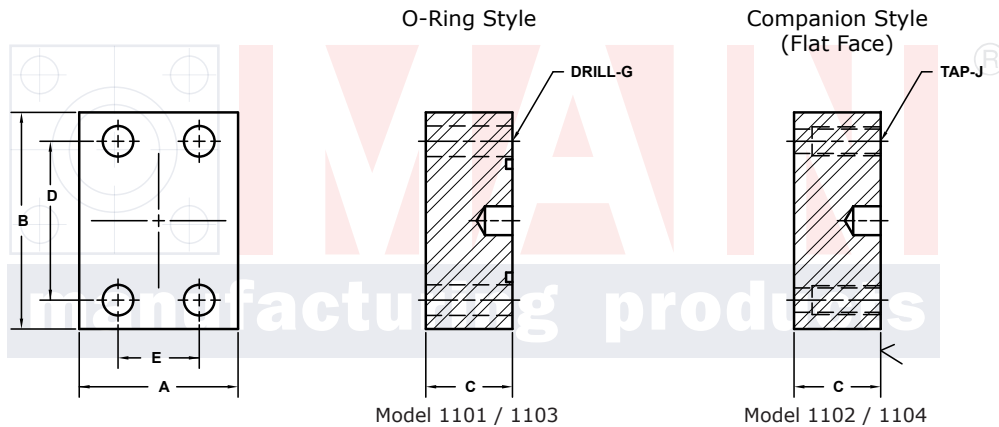

Model 1101 / 1103

Model 1102 / 1104

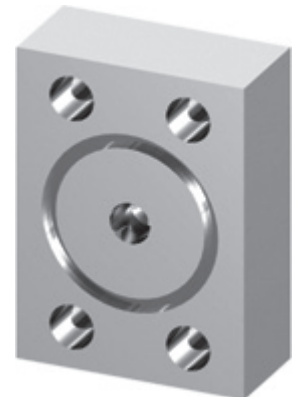

3181 TRI-PARK DR. GRAND BLANC, MI 48439 800-521-7918 810-953-1380 FAX 810-953-1385 INFO@MAINMFG.COM

SAE BOLT PATTERN										62 SERIES				
FLANGE SIZE	PIPE SIZE	PART NUMBER	A	B	C	D	E	G	J	MOUNTING KIT®			WT	
										PART NO.	SCREW SIZE	O-RING		
1/2	NA	1103-08-00	1.75	2.22	1.00	1.594	.718			.34	MK 512	5/16-18 x 1 1/2	210	.9
		1104-08-00								5/16-18	-----	---		
3/4	NA	1103-12-00	2.00	2.81	1.00	2.000	.937			.41	MK 502	3/8-16 x 1 3/4	214	1.4
		1104-12-00								3/8-16	-----	---		
1	NA	1103-16-00	2.25	3.19	1.00	2.250	1.093			.47	MK 513	7/16-14 x 1 3/4	219	1.8
		1104-16-00								7/16-14	-----	---		
1 1/4	NA	1103-20-00	2.75	3.75	1.25	2.625	1.250			.53	MK 514	1/2-13 x 2	222	3.3
		1104-20-00								1/2-13	-----	---		
1 1/2	NA	1103-24-00	3.25	4.50	1.50	3.125	1.437			.66	MK 515	5/8-11 x 2 1/2	225	5.7
		1104-24-00								5/8-11	-----	---		
2	NA	1103-32-00	4.00	5.25	1.75	3.812	1.750			.78	MK 516	3/4-10 x 3	228	9.7
		1104-32-00								3/4-10	-----	---		
2 1/2	NA	1103-40-00	5.00	6.88	2.00	4.875	2.312			.94	MK 517	7/8-9 x 3 1/2	232	18.2
		1104-40-00								7/8-9	-----	---		
3	NA	1103-48-00	6.00	8.50	2.50	6.000	2.812			1.19	MK 718	1 1/8-7 x 4 1/2	237	33.5
		1104-48-00								1 1/8-7	-----	---		

① Order Separately

② 2500 PSI Max

③ 2000 PSI Max

④ 500 PSI Max