

SOCKET WELD PIPE BRANCH TEE FLANGES

SAE BOLT PATTERN										61 SERIES					
FLANGE SIZE	PIPE SIZE	PART NUMBER	A	B	C	D	E	F	G J	H	K	MOUNTING KIT®			WT
												PART NO.	SCREW SIZE	O-RING	
1/2	1/2	1165-08-08	2.00	2.12	1.44	1.500	.688	.50	.34	.38	.860	MK 541	5/16-18 x 2	210	1.3
		1166-08-08							5/16-18						
3/4	3/4	1165-12-12	2.25	2.62	1.70	1.875	.875	.75	.41	.50	1.070	MK 542	3/8-16 x 2 1/2	214	2.2
		1166-12-12							3/8-16						
1	1	1165-16-16	2.50	2.82	1.94	2.062	1.031	1.00	.41	.50	1.335	MK 543	3/8-16 x 2 3/4	219	2.8
		1166-16-16							3/8-16						
1 1/4	1 1/4	1165-20-20	3.00	3.19	2.40	2.312	1.188	1.25	.47	.50	1.680	MK 578	7/16-14 x 3 1/4	222	4.5
		1166-20-20							7/16-14						
1 1/2	1 1/2	1165-24-24	3.50	3.75	2.90	2.750	1.406	1.50	.53	.50	1.920	MK 545	1/2-13 x 4	225	7.7
		1166-24-24							1/2-13						
2	2	1165-32-32	3.75	4.00	3.40	3.062	1.688	1.94	.53	.50	2.411	MK 546	1/2-13 x 4 1/2	228	9.3
		1166-32-32							1/2-13						
2 1/2 ^②	2 1/2	1165-40-40	4.00	4.50	3.96	3.500	2.000	2.44	.53	.50	2.911	MK 547	1/2-13 x 5	232	12.0
		1166-40-40							1/2-13						
3 ^③	3	1165-48-48	5.00	5.31	4.96	4.188	2.438	2.94	.66	.62	3.540	MK 548	5/8-11 x 6	237	22.2
		1166-48-48							5/8-11						
3 1/2 ^④	3 1/2	1165-56-56	6.00	6.00	5.40	4.750	2.750	3.44	.66	.62	4.045	MK 549	5/8-11 x 6 1/2	241	32.5
		1166-56-56							5/8-11						
4 ^④	4	1165-64-64	6.00	6.38	5.96	5.125	3.062	3.94	.66	.62	4.550	MK 550	5/8-11 x 7	245	35.5
		1166-64-64							5/8-11						
5 ^④	5	1165-80-80	7.25	7.25	6.90	6.000	3.625	4.94	.66	.62	5.635	MK 1569	5/8-11 x 8	253	50.7
		1166-80-80							5/8-11						

MATERIAL:
Low Carbon Steel

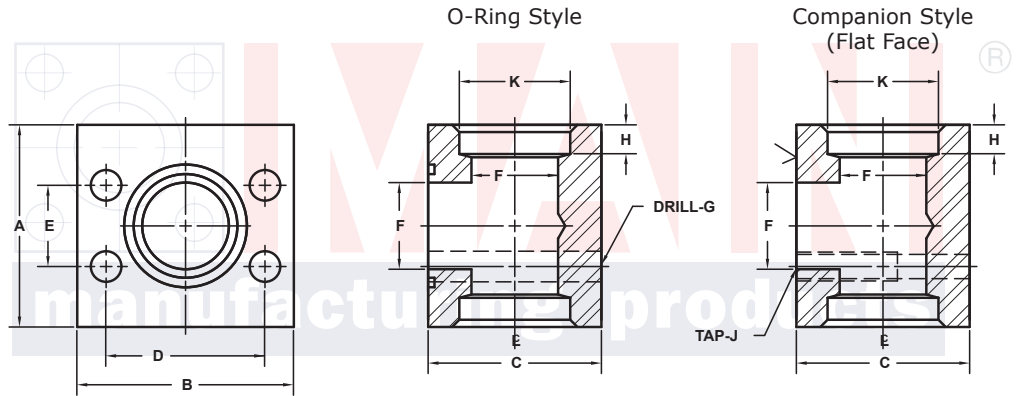
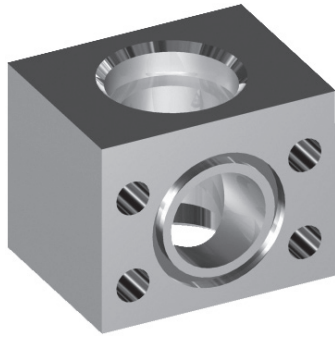

Model 1165 / 1167

Model 1166 / 1168

3181 TRI-PARK DR. GRAND BLANC, MI 48439 800-521-7918 810-953-1380 FAX 810-953-1385 INFO@MAINMFG.COM

SAE BOLT PATTERN										62 SERIES					
FLANGE SIZE	PIPE SIZE	PART NUMBER	A	B	C	D	E	F	G J	H	K	MOUNTING KIT®			WT
												PART NO.	SCREW SIZE	O-RING	
1/2	1/2	1167-08-08	2.00	2.22	1.46	1.594	.718	.50	.34	.38	.860	MK 541	5/16-18 x 2	210	1.5
		1168-08-08							5/16-18						
3/4	3/4	1167-12-12	2.50	2.81	1.70	2.000	.937	.75	.41	.50	1.070	MK 542	3/8-16 x 2 1/2	214	2.7
		1168-12-12							3/8-16						
1	1	1167-16-16	2.75	3.19	2.21	2.250	1.093	1.00	.47	.50	1.335	MK 2533	7/16-14 x 3	219	4.2
		1168-16-16							7/16-14						
1 1/4	1 1/4	1167-20-20	3.00	3.75	2.44	2.625	1.250	1.25	.53	.50	1.680	MK 552	1/2-13 x 3 1/4	222	5.7
		1168-20-20							1/2-13						
1 1/2	1 1/2	1167-24-24	3.50	4.50	2.96	3.125	1.437	1.50	.66	.50	1.920	MK 553	5/8-11 x 4	225	9.7
		1168-24-24							5/8-11						
2	2	1167-32-32	4.00	5.25	3.46	3.812	1.750	1.94	.78	.50	2.411	MK 554	3/4-10 x 4 1/2	228	14.5
		1168-32-32							3/4-10						
2 1/2	2 1/2	1167-40-40	5.50	6.88	4.50	4.875	2.312	2.44	.94	.62	2.911	MK 2557	7/8-9 x 6	232	35.4
		1168-40-40							7/8-9						
3	3	1167-48-48	6.00	8.50	5.00	6.000	2.812	2.94	1.19	.62	3.540	MK 756	1 1/8-7 x 7	237	51.0
		1168-48-48							1 1/8-7						

① Order Separately ② 2500 PSI Max ③ 2000 PSI Max ④ 500 PSI Max